



Sudden Valley Community Association
360-734-6430
4 Clubhouse Circle Bellingham, WA 98229
www.suddenvalley.com

APPROVAL REQUEST MEMO

To: Sudden Valley Community Association Board of Directors
From: Jo Anne Jensen, General Manager
Date: April 25, 2024
Subject: Approval of Acc Policy Revisions

Purpose

To receive approval for the proposed amendments to SVCA's current Architectural Control Committee Policies.

Background

SVCA's current ACC Policies have not been updated or revised since 2020. Since then, the group of people working with these policies on a daily basis have identified sections of the document that lack clarity, include inconsistencies, or are out-of-date with current construction practices. Additionally, some changes have been made to reflect that most lots currently being developed are challenging in some way, with steep slopes, wetlands requirement, or other elements requiring work-arounds.

To assist you in reviewing the proposed changes, we have prepared three documents:

1. A revised copy of the ACC Policies document, with all edits identified using the track changes function;
2. A table listing each section, whether it was revised, and the reason or description of the revision;
3. A Powerpoint presentation sharing the motivation behind the more substantive changes.

The ACC Chair, the full ACC committee, the ACC Inspector, the ACC Administrative Support Specialist, the Maintenance and Facilities Manager, and the General Manager have all reviewed the document and the proposed changes. We feel confident that these changes will improve the quality of this document as a reference for homeowners and builders and will also help to better protect the unique environment of Sudden Valley.

Proposal

I recommend that the SVCA Board of Directors approve the proposed revisions to the ACC Policies document.

Motion

Move that the SVCA Board of Directors approve the proposed revisions to the ACC Policies document.

Approvals

Approved: _____ Not Approved: _____ SVCA Board of Directors

Signed: _____ Date: _____

Keith McLean, SVCA Board President



REVISED: ~~JUNE~~ April
2024

SUDDEN VALLEY



ARCHITECTURAL

CONTROL POLICIES

Quick Reference

Section	Policy No.	Revised
ACC agendas	13.8	07/2015
ACC meetings	13.8	3/2017
ACC structure, powers, purpose, objectives, etc.	13	07/2020
Accessory structures	14.6.5	07/2015
Address	14.11.4, 15.2	07/2015
Area and density regulations	14.5.3	07/2015
Burning	14.6.3	07/2015
Cluster lots	14.5.9	07/2015
Completion deadline	14.7.5	07/2015
Completion deposits for new construction	14.8.9	07/2015
Concrete trucks	14.4.6	07/2015
Construction activities	14.4,	07/2015
Construction submittals	14.8,	07/2015
Construction time limits	14.7.7	04/2017
Contractor requirement/Checklist	14.4, Appendix J	07/2015
Culverts	14.5.7, 14.5.8, Appendix A+B	07/2015
Definitions	Page 4	07/2015
Ditches/Drainage	14.5.7, Appendix K	07/2015
Driveways	14.5.5, Appendix A	07/2015
Enforcement	16	07/2015
Erosion control	14.7.3, 14.9.1(c)(f), Appendix E	07/2015
Exterior finishes	14.6.3	07/2015
Fees	14.8.8	07/2015
Fences	14.6.9, Appendix D	07/2015
Fines	17	07/2015
Fire prevention	14.4.7	07/2015
Foundation/Exposed Concrete	14.6.3(d), Appendix G	07/2015
Garage doors	14.5.5	07/2015
Gardens	14.9.1(l)	07/2015
Hedges/Vegetative fence	14.6.8	07/2015
Height regulations	14.6.2, Appendix B	07/2015
Hours of operation	14.7.1	08/2018
Inspections	14.7.5	09/2020
Landscape maintenance	14.9	07/2015
Landscaping	14.9	07/2015
Lawns	14.9.1	07/2015
Lighting	14.6.4, Appendix F	07/2015
Littering	14.4.3	07/2015
Lot clearing/Excavation	14.7.2	07/2015
Minimum living space/Square footage	14.6.1	07/2015
Noxious weeds	14.9.1	07/2015
Open space requirements	14.5.1 14.5.5	07/2015
Painting	14.6.3(b), Appendix 0	05/2019
Parking	14.2 14.5.6	07/2015

Quick Reference

Section	Policy No.	Revised
Play equipment	14.2,	07/2015
Portable toilet	14.4.2	07/2015
Privacy screens	14.6.9(d)	07/2015
Propane tanks	14.6.8, Appendix H	07/2015
Property coverage	14.5.1	07/2015
Property maintenance	14.11	07/2015
Replacement of damaged structures	14.11.6	07/2015
Retaining walls	14.9.1(d)	07/2015
Right-of-way	14.5.7 (b), 14.9.1 (j)	07/2015
<u>Roofing</u>	14.6.3(c)	07/2015
Setbacks	14.5.2	07/2015
Sheds	14.6.5	07/2015
Siding	14.6.3(d)	07/2015
Signs	15, Appendix L + M	01/2018
Site and lot requirements	14.5	07/2015
Site plan	14.5, Appendix I	07/2015
Speed limits	14.4.4	07/2015
Storage	14.6.5	07/2015
Storm water control/drainage	14.5.8, Appendix C+K	07/2015
Street address	14.6.3(a) 14.11.4, 15.2	07/2015
<u>Structure requirements</u>	14.6	07/2015
Survey	14.8.10	07/2015
Track-type vehicles	14.4.5	07/2015
Trash removal	14.4.3	07/2015
Tree limbing/removal	14.10	07/2015
Utilities	14.8.12	07/2015
Variances	14.8.13	07/2015
Vegetation	14.9.1(a), 14.10	07/2015
Violations	14.4.8, 17	07/2015
Vision clearance	14.5.4	07/2015
Appendices		
Driveway and Culvert Specs.	Appendix A	07/2015
Height Regulations and Definitions	Appendix B	07/2015
Storm water Retention System Design	Appendix C	07/2015
Fence Designs	Appendix D	07/2015
Erosion Control	Appendix E	07/2015
Outdoor Lighting Specs.	Appendix F	07/2015
Exposed Concrete Specs.	Appendix G	07/2015
<u>Propane Tank Regulations</u>	Appendix H	07/2015
Sample Site Plan	Appendix I	07/2015
Checklist	Appendix J	07/2015
Whatcom County Stormwater Plan	Appendix K	07/2015
HOA Information/Dept. of Ecology/National Fire Protection Association	Appendix K	07/2015
Construction Signs	Appendix L	01/2018
For Sale / Rent Signs	Appendix M	01/2018
Sudden Valley Tier Structure for Residence Additions and Structural Changes	Appendix N	02/2019
Pre-Approved Paint Colors	Appendix O	02/2019

ARCHITECTURAL CONTROL COMMITTEE POLICIES FOR DETACHED SINGLE-FAMILY RESIDENCES

In this ~~section document~~ you will find the ~~entire set of~~ Architectural Control Committee (ACC) Policies of the Sudden Valley Community Association. Policies are updated annually, as needed, by the Architectural Control Committee. as revised during 2015 by the Architectural Control Committee and All changes must then be approved by the Board of Directors.

These policies ~~are established by~~ guide the Architectural Control Committee in their review of proposed new construction and exterior alteration projects. The committee is comprised of volunteer property owners elected by the Community. The policies and are enforced by the Administration the Association's General Manager and designated members of S ~~staff. The committee is comprised of volunteer property owners elected by the Community. The Administration Staff is responsible for enforcement of the Restrictive Covenants and ACC Policies but is primarily~~ Staff are also available to help property owners understand how to work within the policy guidelines while achieving their individual ~~desires within the constraints of the~~ goals for their homes.

All property owners are urged required to maintain their lots in a neat and clean manner and in accordance with the regulations of Sudden Valley. With voluntary compliance, costs are reduced, property values are maintained, and Sudden Valley remains a pleasant community in which to reside live.

Sudden Valley Community Association is a collaborative participant with Whatcom County and other local and regional governing agencies in the Lake Whatcom Watershed Management Program. Our ACC policies, which reflect our CC&Rs, ~~are focused on~~ contribute toward sustaining improving the water quality in the Lake ~~Whatcom watershed~~ and maintaining the aesthetic quality of in the community.

Whatcom County issues all permits for construction in the watershed. Project-specific permits, issued by the County, are required by ACC to ensure ~~the Association that proposed projects~~ is are compliant with relevant local, state and federal ~~environmental~~ regulations.

ACC approval is also required for all projects affecting the exterior appearance of a home within the Sudden Valley Homeowners' Association. ~~and ACC approval~~ is not part of the Whatcom County's permitting process and requires that a project satisfy ACC Policies, which may be more restrictive than those of Whatcom County.

DEFINITIONS: The following definitions shall apply for references in ACC_Policies:

Accessory Use or Structure: A use or structure on the same lot with, and of a nature customarily incidental and subordinate to, the principle use or structure.

ADU (Accessory Dwelling Unit): a legal and regulatory term for a secondary house or apartment that shares the building lot of a larger, primary home

Adult: Any individual 18 years of age or older unless otherwise specified.

A-F-A-Frame: A structure whose roof members bear on the ground and carry most or all of the structure's vertical loads to the footings OR whose shape resembles a capital A.

Attached: A structure having all or part of one or more walls common to the dwelling, or a method of attachment approved by the Committee.

Back Fill: To place earth or selected material in any excavated void.

Buffer Area: An undisturbed, vegetated zone that separates manmade structures or activities from natural areas with functional value, usually creeks and wetlands.

Building Area: The total ground area occupied by each building and accessory buildings but not including uncovered entrance platforms, terraces, steps, and decks.

Building Site: The area surrounding the exterior of any structure extending a distance of ten (10) feet from such structure, except when the structure is less than ten (10) feet from the lot line, in which event the lot line shall define the edge of the building site.

Detached: A structure not having all or part of one or more walls common to the dwelling or to a covered porch attached to the dwelling. A structure surrounded by open space.

Easement: A vested or acquired right to use land other than as a tenant, for specific purpose, such right being held by someone other than the owner who holds title to the land.

Established Datum Point (elevation): Point of vertical elevation expressed in feet, which is used to calculate building height, driveway grade and floor elevations. Information provided can be actual (e.g. feet above mean sea level) or relative to a fixed point, conventionally shown as 100 feet (such that downgrade points are not negative numbers).

Finished Grade: The lowest point of the finished surface of the ground, paving or sidewalk within the area between the wall of the building and property line or, when the property line is more than five (5) feet from the wall of the building, between the wall of the building and a line five (5) feet out from the wall of the building.

Floor Area: The total area of all stories or floors finished as living accommodations.

Height, Building: See Appendix B

- (a) The vertical distance from the finished grade (see definition) to the highest point of the coping of a flat roof or the peak of the highest gable of the pitch or hip roof; or
- (b) The vertical distance measured from the highest point on the building site (see definition) to the highest point of the coping of a flat roof or the peak of the highest gable of a pitch or hip roof.

Improved Lot: A platted lot on which presently exists a detached single-family home or upon which construction of such a detached single-family home has commenced.

Interior Living Space: The total area of all finished rooms within a structure (measured according to typical building trade conventions).

Interior Sides: The portion of any lot that lies along the street from which the property address is derived is considered the front side. The side of the lot opposite front is considered the back side. The remaining sides are considered the interior sides of the lot.

Keyway: Association-owned land to be used exclusively for ingress to, egress from, and utilities for the lots having any common boundary with the keyway; may also be used for ingress and egress to park areas.

Lot Line: A boundary line of a lot or parcel.

- (a) Front: The property line separating any interior lot from a street right-of-way. In case of a corner or through lot, the owner may elect any lot line abutting on a street as the front lot line, provided such choice in the opinion of the Committee, will not be detrimental to existing or future development of adjacent properties.
- (b) Rear: All lot lines that do not qualify as either front or side lot lines.
- (c) Side: The two (2) lot lines marking the side limits of the lot and that intersect the front and rear lot lines. The side lot line may intersect the front lot line at any angle and may be of any length.

Lots:

- (a) Corner Lot: A lot that abuts on two (2) or more intersecting streets.
- (b) Interior Lot: A lot that fronts on one (1) street.
- (c) Through Lot: A lot, other than a corner lot, adjacent to more than one street.

Maintenance and Repair: General upkeep, necessary removal, replacement or repair of any existing structural component, surface finish, non-native landscape element, etc., by methods considered conventional in the terms of the trade. Replacement with the same or nearly identical materials, colors and textures.

May: Permission

Manufactured Home: A structure built off-site that has a welded steel underframe and is transported wholly or in sections to the site on its own axles or by trailer.

Modular Home: A home built in whole or in part using structural elements that are assembled off site and transported to the home site by trailer.

Open Space: Unoccupied land that is open to the sky and that may include certain landscaping structures, i.e. retaining walls, planters, etc.

Parking Space: An area measuring ten (10) feet by twenty (20) feet, exclusive of all area used for maneuvering, which is used exclusively for motor vehicle parking.

Privacy Screen: A small section of vegetative or non-vegetative screening that is meant to conceal unattractive objects such as heat pumps, generators, garbage cans, etc. from the view of the street and neighboring homes. It is no larger than is necessary to conceal the specific object.

REPA (Revocable Encroachment Permit Application): A signed REPA allows residents to complete work in the SVCA

Shall: Obligation.

Start Date of Construction: The date on which vegetation, trees, ground cover, etc., are removed and/or excavation is commenced for construction of or addition to a commercial building, single-family home or condominium, or a structure accessory thereto.

Topography: The increase or decrease in elevation above or below the Established Datum Point expressed by lines of contour on a site plan. Slope is depicted by contour interval lines at each point where grade changes up or down by two (2) vertical feet of elevation.

Variance: A modification of the terms of these regulations that may be granted because of the unusual shape, excessive slope or other extraordinary situations or conditions in connection with a specific piece of property when the literal enforcement of these requirements would involve practical difficulties and cause undue hardships unnecessary to carry out the spirit and intent of these requirements.

Viable Water Supply: A reliable and sufficient source of water that can be readily accessed and utilized for firefighting purposes, ensuring an adequate amount of water available to suppress fires effectively during the construction or renovation phase of a building.

13. ARCHITECTURAL CONTROL COMMITTEE:

13.1 - STATEMENT OF PRINCIPLE: In considering the geographic position of Sudden Valley within the Lake Whatcom Watershed, the program for any development within Sudden Valley should consider the rights and interests of its residents, balanced with legitimate concerns for preservation of environmental and aesthetic resources. In addition, the scale and character of the physical development should be consistent with the natural, forested setting in which the community exists. The following descriptions of the Architectural Control Committee (ACC) and its functions are derived from the Restrictive Covenants (RC), which are binding upon all lots in platted divisions and designated condominium tracts within the boundaries of Sudden Valley.

13.2 - COMMITTEE STRUCTURE: The Architectural Control Committee shall be composed of at ~~least five~~nine (9) members of the Sudden Valley Community Association in good standing who are elected to serve until their successors are elected. elected by the Community. Alternates serve one (1) year term. Members of the Committee shall serve rotating three (3) year terms staggered such that only three (3) members are to be elected each year. Meetings shall be held twice monthly on dates designated by the Committee (RC #4).

13.3 - POWERS: The Committee shall have the right to disapprove any plans, specifications or details submitted to it in the event the same are not in accordance with all provisions of these Policies; if the design or color scheme of the proposed building(s) or other structure(s) is not in harmony with the general surroundings of such property or with adjacent buildings or structures; if plans and specifications are incomplete; or in the event the Committee deems the plans, specifications, details or any part thereof to be contrary to the interests, welfare or rights of all or any part of the real property subject hereto, or the owners thereof. The decisions of the Committee shall be final (RC#4). The Committee considers each property individually and variances granted in one situation may not be granted in another.

13.4 - COMMISSION: Plans and specifications for any structure or improvement to be erected on platted property within the boundaries of Sudden Valley, the proposed location on the subject property, the materials, roofs, and exterior color schemes, any later changes or additions after initial approval, and any remodeling, rebuilding, alterations or additions thereto shall be subject to and require the written approval of the Committee before such work commences. **ACC approval requests for exterior alterations to a developed property shall be submitted to the SVCA Administration no later than noon one (1) week seven (7) business days prior to a scheduled ACC meeting. Completed projects shall be revisited and reviewed by an ACC member the Architectural Control Inspector, or other designated member of SVCA Staff, to note the final project status and adherence to approved plan and specifications.**

13.5 - AREA OF RESPONSIBILITY: The Committee shall concern itself with the overall planning, specific sites and building aesthetics. In no way shall the Committee confirm assumed geological condition, structural method proposed nor the general adequacy of safety of any proposed structure(s).

13.6 - PURPOSE:-The purpose of the Committee shall be to ensure the highest possible degree of harmony between natural and manmade systems, and that continued development does not unduly diminish the quality and aesthetic integrity of both the natural and built environments.

13.7 - OBJECTIVES: The objectives of the Committee shall be:

- (a) To create and maintain an aesthetically desirable community by encouraging sensitive architectural design of the individual residences, recreation retreats, signage, condominiums, commercial structures and related facilities.
- (b) To encourage maximum creative architectural response to each individual site as well as to the area and region.
- (c) To protect individual property owners from the results of indiscriminate construction by others that would adversely affect surrounding property values and the general aesthetic quality of Sudden Valley.
- (d) To review plans for any single-family home or condominium planned for Sudden Valley and the setting of each tract considering land use, environment, traffic and amenities, and other elements as delineated in the Restrictive Covenants for Sudden Valley Condominium Tracts and Commercial development regulations. (Information, Covenants, Rules and Regulations pertaining to Condominium and Commercial development are published under separate cover and are available through the Administration.)⁷

~~(d)~~

13.8 - CONDUCT OF MEETINGS: ACC meetings are held on the first and third Thursday of each month, unless otherwise announced. To accommodate as many members as possible, the meeting on the first Thursday will be at 9:00 AM and the ~~THIRD~~-third Thursday will be held at 6:00 PM. A majority of all committee members, ~~excluding alternates~~, shall constitute a quorum. Meetings are open to all members in good standing whose written and/or oral comments will be accepted and taken into consideration by the Committee during discussion and final decision of a proposal. The agenda is available at the Administration office in the Clubhouse and is also posted on the SVCA website at least 24 hours prior to each regular meeting. Owners and residents are encouraged to stay informed about pending development activities through this process. Written notice of Committee decisions normally is available within ~~ten-fourteen~~ (14) working days after the meeting date. Minutes of the meetings normally are ~~posted to the SVCA website available at the Administration office and are posted on the SVCA website no later than five-one~~ (5) working days following the meeting at which they are approved. Decisions of the Committee are final (Restrictive Covenants #4).

14. POLICIES FOR DETACHED SINGLE-FAMILY RESIDENCES:

14.1 - INTENT: These policies are intended to help property owners design, build and maintain single-family homes that will meet the intent of the Committee's objectives. ~~Implied in these objectives are a desire to avoid a "tract-like" appearance in Sudden Valley and therefore, repeating the same house plan will be discouraged.~~ One important aspect when selecting a design is the lot itself. Rather than reshaping the lot to fit the house, the size, shape and topography of the lot should dictate design characteristics. Given the unique nature and variability of each lot, it should be possible to achieve diverse architectural designs while maintaining a high degree of sensitivity to the natural environment. ~~While it may not be economically feasible for every lot owner to employ a professional designer, it is recognized that there are sufficient numbers of "off the shelf" (stock) plans, which, when modified, should satisfy constraints regarding aesthetics, open space and tree preservation.~~

14.2 - SCOPE: Changes that affect the exterior appearance of a house or lot including new construction, additions, parking spaces, fences, outdoor play equipment, sculptures, retaining walls, and any other exterior features shall require prior approval by the Committee. The community places a high value on preservation of healthy native trees and natural features. With

respect to the degree to which lot size and structure design affect tree removal, the Committee is empowered to deny approval of plans or require redesign or relocation of the structure on the lot based on tree preservation and/or environmental concerns. ~~Neither "A-frame" houses nor "Manufactured Homes (see definitions)" will not be considered by the Committee, but Modular Homes (see definitions) may be considered dependent on the site and configuration.~~ ~~be approved.~~ The Committee ~~recognizes that the construction industry is rapidly changing and~~ recommends that property owners or contractors wishing to use new construction technologies or requiring significant variances first submit an in-concept request for pre-approval prior to making substantial investments in plans or permits (see section 14.8.3). **It is recommended that all residents familiarize themselves with the contents to better understand the requirements pertinent to home structure and maintenance.**

14.2

14.3 - COMPLIANCE REVIEW: In order to verify that all proper permits have been obtained, the property owner or his/her designee must provide to the Administration the original Whatcom County stamped and approved plan set and building permit **prior** to commencement of construction. Only after such verification and payment of the Completion Deposit will SVCA issue final approval to proceed, and such approval to proceed will include any conditions or reservations imposed by the Committee and SVCA Maintenance & Facilities Manager. Both Whatcom County AND Sudden Valley approved plan and permits must be consulted to ensure compliance to all regulations and permit conditions. **NOTE: Failure to obtain SVCA authorization to proceed prior to commencement of construction will result in issuance of a Stop Work Order and Notice of Violation to the owner. For Contractor's Checklist, see Appendix J.**

14.4 - CONTRACTOR AND OWNER/BUILDER REQUIREMENTS FOR CONSTRUCTION ACTIVITIES:

14.4.1 Licensing Requirements: Other than direct employees of Sudden Valley, any individual or company performing work or providing contracting services within Sudden Valley shall possess a current and valid State of Washington General or Specialty Contractor's License and Bonding, and when requested, provide to the Association proof of such valid license and bond.

Any individual or company applying for approval of new construction, repair, or substantial remodeling projects within Sudden Valley shall provide to Administration Staff a current and valid State of Washington General Contractor's license (unless it is owner-built for owner use, in accordance with exceptions to state licensing requirements). A Certificate of Insurance evidence in general liability coverage of at least one million dollars (\$1,000,000) for new construction projects and five hundred thousand dollars (\$500,000) for additions shall also be provided.

- (a) Any contractor working in Sudden Valley who violates on three (3) or more occasions the Bylaws, Restrictive Covenants, Rules and Regulations, or the ACC Policies such that his/her actions may be considered flagrant, or is the subject of any criminal or civil action for license violations, breach of trust, fraud or other illegal or unethical activities, may be subject to official censure by the Association's Board of Directors and thereafter limited or denied access to Sudden Valley property.
- (b) Any unlicensed contractor or subcontractor performing work for compensation may be prohibited access to Sudden Valley until evidence of such licensure is verified.
- (c) SVCA may report to the proper authorities any known or suspected incidence of illegal contracting activity.

14.4.2 Portable Toilet: The owner or contractor shall provide on the building lot one (1) temporary portable toilet facility, equivalent in sanitary effectiveness to a "Port-O-Let," placed no closer than five (5) feet from the roadway and in a location least offensive to people in adjoining homes or on the Golf Course. It shall remain in place until such time as the house toilet facilities are operable.

14.4.3 Trash Removal: The owner or contractor shall provide on the building lot an adequate container for the placement of trash. The contractor shall ensure that its workers, as well as those of its sub-contractors, make proper use of the container. The contractor or owner shall be responsible for removal and proper disposal of all unwanted construction and clearing debris from the site, and such removal shall coincide with construction. Littering of the job site and adjacent properties with lot-clearing debris or builder's trash, bottles, cans, paper wrappers, plastic, etc., is strictly prohibited and subject to notice of violation. Burying trash or organic debris anywhere on or off the lot or adjacent properties is **prohibited**.

14.4.3

14.4.4 Speed Limits: The posted speed limits and all traffic laws must be observed by the builder and the sub-contractors to preserve their privilege of access to Sudden Valley.

14.4.5 Track-type Vehicles: Track-type vehicles (with either grouser or "street" tracks), concrete pump or bucket truck metal outrigger pads shall not be permitted in direct contact with paved surfaces. Appropriate protection must be placed under the tracks or pads to prevent direct contact.

14.4.6 Concrete Trucks: Concrete trucks and pumps shall only be cleaned or washed out onto the jobsite property, within the impervious boundaries of the foundation. Such material shall not be discharged or permitted to flow onto roadways, driveways, undisturbed/natural or landscaped areas, adjacent properties, ditches, or right-of-way. Also, due to the steep grade of many roads in Sudden Valley contractors and/or owners of the project must ensure that concrete trucks delivering in Sudden Valley do not overfill their drum, thus causing concrete to spill. Thus, it is suggested that one yard be reduced from the fill capacity of any drum. Any spillage must be cleaned up immediately. Citations may occur if spill is due to negligence.

14.4.7 Fire Prevention: Contractors shall have a fire extinguisher, rated not less than 2A, - on site at all times. A spark arrestor must be installed on all relevant pieces of equipment used in construction. A viable water supply with an attached 3/4-inch hose of adequate length must be available at all construction sites ~~at the time of footing and floor elevation inspection~~ as soon as combustible materials arrive on site.

14.4.8 Violations: **It shall be the property owner's responsibility to ensure that any contractor performing work on the owner's behalf complies with these rules.** Violations of the Restrictive Covenants, these Rules and Regulations, or the Architectural Control Committee Policies will be called to the attention of the contractor and property owner, and a fine may be assessed accordingly. The property owner shall receive a Notice of Violation for infractions and shall be responsible for repair of any property damage resulting from actions of the contractor. Any outstanding violations or fines must be resolved or paid before new permits or change requests will be processed for either the contractor or the property owner. The property owner will ultimately be held responsible for any fines assessed.

14.5 SITE AND LOT REQUIREMENTS: For Whatcom County Stormwater Management Plan information please see Appendix K.

14.5.1 Property Coverage and Open Space Requirements: Measurements for determining these percentages shall be measured on a horizontal plane.

- (a) Property Coverage Rule - The principle building and accessory structure

footprint, inclusive of eave projections and driveways and exclusive of ~~driveways and~~ decks, shall occupy no more than thirty-five percent (35%) of the lot.

- (b) Open Space Rule - At least fifty percent (50%) of the lot shall be kept free of all structures, including but not limited to all areas covered by weather-tight roof, decks, steps, driveways, hard surfacing and parking areas.
- (c) The minimum fifty percent (50%) open space as required herein shall be a continuing obligation. Such space shall be maintained with porous ground cover, and no parking or storage of materials shall be permitted in the open space.
- (d) Special rules apply to Cluster lots, see section 14.5.9.

~~(d)~~

14.5.2 Minimum Setbacks: Setbacks will be measured to the structure where **roof, projections and decks** are defined as being included in the structure. Minimum setbacks for later platted divisions may be more restrictive. See the covenants for that specific division. The Whatcom County Zoning Ordinance (Title 20) shall apply in the event its minimum setbacks are greater (more restrictive). Prospective builders are urged to consult Whatcom County zoning officials prior to site plan preparation

Minimum Sudden Valley setbacks are as follows:

Front - Twenty (20) feet from right-of-way

Rear - Five (5) feet.

Interior Side — ~~At least five (5) feet;~~ combined interior side setbacks must be at least twenty (20) feet.-

Side Yard on an Adjacent Street - Twenty (20) feet from right-of-way margin, where feasible.

Cluster Lots - Special rules apply to Cluster lots see section 14.5.9.

Environmentally Sensitive Areas – Distances are subject to change. Please refer to Whatcom County for site-specific setbacks and most current regulations.

Non-fish bearing streams - Fifty (50) ft.

Fish bearing streams – One-hundred (100) ft.

Shoreline streams – One-hundred fifty (150) ft.

Shorelines – One-hundred (100) to two-hundred (200) ft. depending on activity

Ponds – Fifty (50) ft.

Lakes – One-hundred (100) ft.

Wetlands – Twenty-five (25) to three-hundred (300) ft. depending on the wetland classification and activity

14.5.3 Area and Density Regulations:

- (a) No building or structure, nor the enlargement of any building or structure, shall be permitted or located on any lot unless in conformity with these area regulations.
- (b) No platted lot now existing or hereafter established shall be subdivided, reduced or diminished in size such that yards, open space or total area be made smaller than the minimum required by these regulations; nor shall any lot or parcel of land that is now smaller than the minimums required by the regulations be further reduced or diminished in size by any grant or action.

14.5.4 Vision Clearance:

- (a) All corner properties shall maintain a clear triangle at the intersecting street right-of-way. This area shall contain no planting, fence, wall, vehicles, temporary or permanent obstruction exceeding thirty (30) inches in height, measured from the mean grade of the intersecting streets except that trees exceeding this height may be located in this area, provided all branches and foliage are removed to a height of ten (10) feet above grade.

- (b) One angle of this triangle shall be formed by the intersecting street right-of-way. The sides of the triangle measured along the property lines from said angle shall be twenty (20) feet in length. The third side of such triangle shall be a straight line connecting the ends of the two aforementioned lines.

14.5.5 Driveways:

- (a) Driveways must not intersect streets or thoroughfares within thirty (30) feet of an intersection.
- (b) The first five (5) feet of any driveway connecting with an SVCA road shall be paved and flush with the roadway edge, using either asphalt or concrete to reduce "loose rock" damage to SVCA roads and reduce the hazard to two (2) wheeled vehicles.
- (c) All driveways where the slope exceeds 10% (i.e. over 6 degrees uphill) must be paved from the edge of the paved right-of-way to the property line or fifteen (15) feet, whichever distance is greater.
- (d) Where there is positive grade (uphill) from the street, driveway approaches should be properly configured to prevent storm water or domestic water from flowing onto the roadway below by construction of a swale, 4-inch minimum width strip drain or other approved catch basin (see Appendix A). Similarly, where the grade of the driveway slopes downhill towards the home a strip drain must be installed in front of the garage, which connects to the home's footing drains.
- (e) Driveways and keyways shall be constructed to minimum SVCA standards. Minimum driveway width is twelve (12) feet and maximum width is twenty (20) feet (Appendix A).
- (f) A maximum driveway slope shall not exceed ~~15.25%~~, without a variance A maximum driveway slope of up to 20% may be approved, dependent on the site, if the driveway is grooved or if other measures are taken to ensure that the driveway remains safe. (Appendix A).
- (g) A driveway turn-around and/or curb may be required in situations with identified safety concerns.
- (h) Treated timbers or other suitable edging shall be placed along crushed rock driveways to define access and parking areas and to contain and minimize the scattering of rock. Timbers treated with creosote are not permitted.
- (i) Complete replacement of existing driveway requires **ACC approval** as well as on-site inspection by the Administration Staff prior to implementation.

14.5.6 Parking: Creating or installing additional parking capacity requires prior **ACC approval**.

- (a) Each single-family dwelling shall have a minimum of two (2) parking spaces, at least one (1) of which shall be enclosed in an attached garage.
- (b) ~~The committee discourages~~ Parking in the SVCA Right of Way (ROW) is discouraged. If parking in the right-of-way or creating parking spaces in the right-of-way is proposed, especially where there is a ditch the approval of the SVCA Maintenance & Facilities Manager must be obtained before it can be reviewed by the Committee. This approval can be obtained through the REPA process (refer to SuddenValley.com).
- (c) All garages shall be constructed to allow a minimum of twenty (20) feet of driveway between the garage door and the property line.
- (d) Special rules apply to Cluster lots see section 14.5.9.

14.5.7 Drainage/Biofiltration/Rain Gardens: Grass or rock-lined open ditches shall be preferred over culverts (covered pipe systems), due primarily to the limitations of open ditches to capture runoff from the road surfaces and to provide for the energy dissipation and infiltration of runoff. Modifications to the existing ditch, including culvert installation or extensions, ~~require~~ must be approved by the SVCA Maintenance & Facilities Manager before being considered

by the Committee. ~~ACC approval.~~ This approval can be obtained through the REPA process (refer to SuddenValley.com).

- (a) New culvert installations shall be the responsibility of the property owner.
- (b) Within SVCA road right-of-way, ~~maintenance of properly installed culvert pipes shall be the responsibility of the Association.~~ The abutting property owner is responsible for culvert maintenance, including keeping ditches and ends of culvert pipes clear of debris that could impede water flow. Should replacement or repair of any damaged or improperly installed culvert become necessary, it shall be the responsibility of the abutting property owner to replace or repair said culvert upon notice from SVCA.
- (c) The Drainage System Master Plan for SVCA (Bell-Walker, 1982) and Whatcom County Code, together ~~with~~ sound engineering principles, shall be the basis for establishing minimum culvert sizes, specifications, and other requirements for any given application.
- (d) In addition, installation of all drainage culverts, culvert extensions and diversions shall be subject to certain minimum standards judged appropriate to the site by SVCA. The culvert pipe shall be corrugated metal, concrete, ~~or~~ double wall ADBS, PVC, Ductile Iron, or HDPE pipe. The minimum diameter allowed is twelve (12)-inches. Embankment next to the ends of the pipe shall be sealed or rip rapped to prevent erosion (Appendix A).
- (e) A concrete catch basin, type one (1) with cleanout, shall be installed every 40 linear feet of culvert and at any change in the culvert's horizontal or vertical alignment.

14.5.8 Storm Water Drainage: Storm water drainage resulting from roof, parking and driveway areas shall be diverted into an appropriate drainage system.

- (a) For single-family residences, the storm drainage collected from roofs and driveway areas shall be piped into an on-site drainage retention/detention system which meets the minimum standards established by the SVCA engineer or other applicable public agencies (Appendix C).
- ~~(a)~~(b) Storm water (including system overflows and sump pumps) shall not be permitted to flow into the sewer collection system.
- ~~(b)~~(c) System cleanout/sump shall be inspected and cleaned by the owner periodically to ensure proper functioning.
- ~~(c)~~(d) Those systems found to be faulty or malfunctioning shall be required to be repaired (at the owner's expense) to a level of function applicable to standards in effect at the time of original installation.
- ~~(d)~~(e) Additions to existing homes, new garages, etc., may require construction, enlargement and/or other modification of a storm water retention system to ensure adequate capacity and function.

14.5.9 Special Rules for Cluster Lots: Cluster lots are defined as platted lots that are adjacent to a common platted parking area that usually serves four (4) or more lots.

- (a) The thirty-five percent (35%) property coverage limitation shall not apply to cluster lots.
- (b) The open space requirement remains at fifty percent (50%); however, for purposes of calculating the allowed coverage, the square-foot area corresponding to the undivided interest in the adjacent parking area is included in the calculation to determine the allowed coverage.
- (c) The square-foot area corresponding to the undivided interest in the adjacent parking area used in the calculation cannot be greater than half the actual lot size.
- (d) Cluster lot, open space calculation method.

Example: For a 3000 sq. ft. cluster lot, adjacent to a 4000 sq. ft. parking area that serves four

(4) cluster lots.

3,000 sq. ft. Cluster lot size

1,000 sq. ft. 1/4 undivided interest in 4000 sq. ft. parking area (4000 ÷ 4 but not greater than 3000 ÷ 2)

4,000 sq. ft. Total square footage used for calculating 50% rule.

Example: For a 3000 sq. ft. cluster lot, adjacent to an 8000 sq. ft. parking area that serves four (4) cluster lots. In this example the undivided interest in the parking area calculation is limited by the requirement of subsection (c).

3,000 sq. ft. Cluster lot size

1,500 sq. ft. ¼ undivided interest in 8000 sq. ft. parking area (8000 ÷ 4 but not greater than 3000 ÷ 2)

4,500 sq. ft. Total square footage used for calculating 50% rule.

(e) Cluster lots minimum setbacks – Setbacks will be measured to the structure where **roof projections and decks** are defined as being included in the structure. The setback from the road right-of-way margin for a cluster lot is twenty (20) feet. When the house is facing the platted parking area and the driveway access is from the platted parking area, a side setback to the road right-of-way margin of less than twenty (20) feet may be considered. All other setbacks are five (5) feet minimum to the eaves. Setbacks for cluster lots not adjacent to the road right-of-way margin are five (5) feet minimum to the eaves on all sides.

14.6 Cluster lot parking requirements - Each single-family dwelling shall have a minimum of two (2) parking spaces one of which shall be enclosed in the form of an attached garage. All garages shall be constructed to allow a minimum of twenty (20) feet of driveway between the garage door and the adjacent platted parking area where feasible. **STRUCTURE**

REQUIREMENTS:

14.6.1 Minimum Interior Living Space: For all new construction, a minimum finished interior footprint of one thousand (1000) sq. ft. ~~exclusive of garage(s)~~ is required. Total interior finished living space across all floors must total 1,000 sq. ft. or more. Carports are discouraged. Variances to this requirement may be allowed for special circumstance.

14.6.2 Height Regulations: Maximum structure height shall be thirty (30) feet under Definition I or twenty (20) feet under Definition II (see Appendix B). Height limitations for platted divisions may vary according to the covenants for that specific division. Review of building heights are on an individual basis and shall not be based on any previous approval. Proximity to neighbors will be a consideration in determining height limits.

The owner, upon application, may elect either height definition, but structures shall not exceed the height limits as specified.

14.6.3 Exterior Finishes: Exteriors shall be composed of materials compatible to surroundings and in keeping with the Committee purposes and objectives (see sections 13.6 and 13.7).

(a) **For reason of safety and security, the house number must be clearly visible from the street.**

(b) **PAINT COLORS** - The use of "subdued" exterior colors that are compatible with the neighborhood and environment is required. Approval of owner selections shall be discretionary with the Committee and be limited to specific site applications. Approval of a color in one location does not necessarily mean the color is deemed approved for all locations. Custom colors are approved or disapproved based on other criteria, including possible negative contrast with

surrounding areas.

- (1) Structures found to be in noncompliance with these color policies may be required to be repainted immediately following their discovery and notice of noncompliance from the Association.
 - (2) If painting is not completed within six (6) months of approval, applicant shall resubmit the request to the Committee.
 - (3) An approved color pallet is available at the Sudden Valley Administration Office. Should a resident choose a color from the approved pallet the ACC Coordinator will approve the request immediately upon receipt of the exterior alteration and then no further action is required prior to the commencement of work. Any colors not contained in the approved color pallet (see appendix "O") require the ACC Committee review and approval prior to commencement of work.
 - (4) Unless otherwise approved, garage doors and panels are considered part of the body of the house for paint purposes. Any color deviating from the body color of the residence requires prior ACC approval. Trim and accent colors are not approved garage door colors unless specifically approved by the ACC.
- (c) **ROOFING** - Roofing materials should be of fire-resistant materials and may consist of asphalt/fiberglass shingles, cement tiles, composites, metal and/or other specialized roofing materials subject to Committee approval. Wood shingles, shakes, or corrugated roofs are not permitted. Shake roofs with a Class-A fire rating may be permitted with prior approval from the Committee. Type and color choices for all materials shall be submitted to and approved by the ACC prior to application on any residence, addition or accessory structure. The Committee will not approve a submission for partial re-roofing with a material or color that is different than the existing roof. The re-roofing of a structure using asphalt/fiberglass shingles in the shades black, grey or brown shall be considered routine maintenance and not require committee approval.
- (d) **SIDING** - Siding may consist of wood or wood products, fiber-cement-based products, rock and/or brick veneers, and stucco (when combined with other approved siding types). No asphalt, aluminum, or vinyl materials shall be used or approved for use as siding. Samples of the proposed material may be requested by the Committee. Approval of any non-conventional material(s) shall be discretionary and may be limited to that specific site. All siding types and installation must meet current building codes.
- (e) **FOUNDATION** - Exposed concrete shall not exceed a maximum of 12" from level finished grades to bottom of siding. For stepped foundation walls, exposed concrete shall not exceed a maximum of 24" at any point or an average of 18" from sloped finish grades to bottom of siding. Where exceeding any of these maxima is unavoidable, foundations shall be finished in character consistent with Section 14.9.1(d) of the ACC Policies. [Painting the foundation wall the body color of the house is generally acceptable in small areas.](#) See Appendix G for more information.
- (f) **MISCELLANEOUS**. - Metal chimneys, "B-vent" and plumbing stacks that exceed thirty (30) inches in height measured from the lowest point of roof penetration or that extend below the roofline on the exterior sidewall shall be enclosed in an approved box or "chase." That portion that is left exposed shall be painted flat black or brown.
- (1) All other exposed metal flashing shall be painted an approved color

- (2) Code-approved spark arrestors MUST be provided on all chimneys connected to wood burning appliances.

14.6.4 Exterior Lighting: The purpose of exterior lighting is to make safe movement possible and to enhance aesthetic qualities of the structure and its surroundings. Poorly designed lighting can extend well beyond the boundaries of the area in which it is installed and become a nuisance to neighbors. All existing and proposed exterior lighting must be directed downward and bulbs must be shielded from view using enclosures or frosted glass. Though there are many needs for exterior lighting in our community, obtrusive aspects of lighting can extend well beyond the boundaries of the area in which the lighting is installed and intended for use. These obtrusive aspects can be effectively controlled or eliminated with carefully considered attention to design, installation and use. All existing and proposed exterior lighting must conform to Appendix F, Section 1.

- (a) Lights activated by motion detectors shall be adjusted where possible to minimize inadvertent or constant activation by normal adjacent activities.
- ~~(b) Mercury vapor lights will be approved only where deemed appropriate and require specific approval by the Committee. Flat panel LED style floodlights are prohibited.~~
- ~~(c)~~ (b) Exterior lighting found to be objectionable to neighboring residences or commercial interests may be appealed to the Committee for review. ~~If lighting projects are not completed within six (6) months of approval, applicant shall resubmit the request to the Committee.~~

14.6.5 Accessory Structures: All construction of sheds, storage areas or other accessory structures requires prior ACC approval. Accessory structures ~~shall be attached to the proposed or existing residence, except where attachment is impractical due to topography or other reasons acceptable to the Committee and~~ must meet minimum setback requirements (see section 14.5.2). In no case shall structures be supported by or attached to trees.

- (a) All accessory structures (garage, storage, woodsheds, etc.) shall be consistent with the main structure in terms of architectural character, materials and finishes.
- ~~(b) All outside storage areas must be screened from view of adjacent properties and roads. This includes areas for storage of trash and recycling containers, lawn equipment, garden tools, construction materials and other maintenance supplies or equipment under decks where such areas are used to store any type of materials, or any area on the lot where materials are being stored.~~
- ~~(c) Except where otherwise specifically approved, the total area on each lot utilized for such outside storage Sheds may not exceed one hundred (100) square feet in area, nor can it reduce in area the required minimum fifty (50) percent open space (see 14.5.1). If accessory structures are not completed within six (6) months of approval, applicant shall resubmit the request to the Committee.~~

14.6.6 Solar Panels: Installation of roof-mounted photo-voltaic solar panels requires prior ACC approval. The property owner must ensure that both local utility companies' and Whatcom County's requirements are addressed.

14.6.7 Hot Tubs: Installation of hot tubs may require building and plumbing permits from Whatcom County and any necessary permits shall be obtained prior to submittal to the ACC for final approval. Information may be obtained from the Whatcom County Planning Department. Hot tubs must be screened from view of adjacent properties and roads by a privacy panel or similar design consistent with the design of the main structure (house).

14.6.8 Propane Tanks: Installation/relocation of propane tanks requires prior ACC approval.

- (a) If intended as fuel for a residence to be constructed, the plans and specifications shall

include location of the propane tank on the site plan with details for appropriate tank screening. Free-standing propane tanks will not be allowed in front of the house or on any side of the property facing a street unless they are buried or a variance is given. Smaller, vertical propane tanks may be mounted on the side or rear walls of the residence with appropriate screening.

(b) Screening may consist of an appropriate enclosure and/or deer resistant vegetation. Solid screening is not recommended unless design meets local fire code. The enclosure must be open on the top and have at least four (4) inches of clearance above the ground for proper ventilation. Design and color treatment of the enclosure must have Committee approval. Deer resistant plant materials utilized as screening must be of a perennial, evergreen species of sufficient initial height and fullness to provide complete screening of the tank at the time of final inspection.

(c) Propane tank and screening installations shall meet all federal, state and county regulations. See Appendix H for more information.

14.6.9 Fences: Construction or installation of fences requires prior ACC approval. The design and concept of Sudden Valley is one that promotes and emphasizes continuity of open space for the benefit of both human and wildlife populations. Applicants are strongly encouraged to notify their neighbors of proposed fences prior to applying to the ACC for approval. Each submittal will be treated on a case by case basis. The decision shall be based on the following criteria:

- Topography of the lot.
- Lot size and shape.
- Intended use, i.e. privacy, protection, animal enclosure.
- Additional considerations specific to the proposal (positive or negative impacts to neighboring properties).
- Aesthetics and staked outline of fence.
- ~~No wire fences will be approved except as listed in Appendix D. (No chain link fences allowed.)~~

(a) **Design Elements and Placement Requirements:** See Appendix D for examples of fence design.

- (1) Existing vegetation may not be removed to accommodate any hedge or fence without prior approval; ~~and application for such must be made part of the original request. if requested, it must be included in the original Fence Request Form.~~
- (2) No tree shall be used for the attachment or support of any fence of any kind.
- (3) Yard perimeter fences are discouraged.
- (4) Fences shall not encroach into setback areas (see section 14.5.2) without requesting a variance.

(b) **Living (vegetative) Fences:**

Where there is a desire for privacy between or among adjacent properties, living fences or hedges ~~composed of native evergreens, or a combination of specimen and native plants~~ are encouraged. ~~Living fences, whether planted or cultivated using native vegetation must be approved by the ACC.~~ Such hedges may be planted or cultivated only to the extent that they can be and are maintained by the applicant property owner and will not encroach onto the neighboring lot nor grow to excessive heights (height limits may be imposed to preserve views enjoyed by adjoining properties).

(c) **Non-vegetative Fences:**

- (1) Solid fencing will be discouraged for most situations within Sudden Valley.
- (2) No non-vegetative residential fence may exceed five (5) feet in height from ground level. Fences on constructed or natural berms shall not exceed five

(5) feet, including the height of the berm. Where the lot abuts on a county road, the height limit may be six (6) feet. All residential non-vegetative fencing shall be composed of materials that blend with the native background. Approval will depend upon fence style, aesthetic qualities and structural integrity of each individual proposal, and with an emphasis on consistency within the local neighborhood area. See Appendix D for more information.

- (3) Vegetative screening may be required to break up the outline of the fence from adjacent lots and the street.
- (4) **Above-ground electric fences are not allowed in Sudden Valley.** Underground electric fences, such as Invisible Fence, are acceptable for pet enclosures and do not require prior ACC approval.
- (5) Temporary fences to protect individual trees or plants from animal damage do not require ACC approval. Green, brown or black wire is encouraged for these fences. Homeowners must remove such fences within one (1) year or apply to the Committee to keep them for a longer period.

(d) Privacy Screens:

Maximum size of a privacy screen shall be six (6) feet high by eight (8) feet long. ~~Solid screens are discouraged.~~

~~(e) **Submittal Process:** Fences, hedges, pet enclosures, privacy screens, etc. require prior approval from the ACC. Landscape plans are not to include fencing; separate application must be submitted for fencing requests. **Review of fence requests are on an individual basis and shall not be based on any previous approval or pre-existing fence.**~~

- ~~—Application forms are available from the SVCA administration office or SVCA website. — Applications to the Committee should have the following:~~
- ~~—Name, date, division/lot, **street address**, mailing address, and phone number.~~
- ~~—Description (including dimensions) of fence or hedge material and design.~~
- ~~—Description of intended use of fence or hedge.~~
- ~~—Submittal of a site plan depicting the location on the lot of the proposed hedge or fence with dimensions of both the fence and the distance from the fence to property line.~~
- ~~—Additional information you would like the Committee to consider.~~

~~**Also required:**~~

- ~~—Corners of the proposed fence need to be staked prior to submittal.~~
- ~~—Complete a utility locate before breaking ground.~~
- ~~—If fences are not completed within six (6) months of approval, applicant shall resubmit the request to the Committee.~~

14.7 - COURSE OF CONSTRUCTION ACTIVITY:

14.7.1 Hours of Operation: See Board policy 2018.03.

Contractors performing work that generates noise beyond their property boundaries are seasonally restricted to specific hours during the year.

- a) Summer hours are in effect May 1 through October 30
 - o Monday through Friday: 8:00 AM to 7:00 PM with exception of concrete work
 - o Saturday 8:00 AM to 6:00 PM with exception of concrete work
- b) Non-summer hours are in effect November 1 through April 30
 - o Monday through Saturday 8:00 AM to 6:00 PM
- c) Work crews may begin preparation no earlier than 30 minutes before starting time
- d) Sunday, holiday, and evening work shall be limited to activities that exclude all machinery noise, i.e., chainsaw, excavators, power tools, etc., unless such tool use cannot be detected beyond the property boundary

- e) Concrete placement hours (full year)
 - o Monday to Saturday: mobilization and placement 8:00 AM to 6:00 PM
 - o Exceptions can be made; please contact Administration
- f) Contractor notification requirement for concrete placements:
 - o 48 hours notice to all homes directly adjacent, diagonal, and opposite work location. Additionally, if a full road closure is needed and will block egress for other homes, those homes must also be notified.
 - o Notice must be provided in writing; signs must be placed on doors 48 hours in advance of earliest pour date. For closures affecting large numbers of residents, a traffic control plan and road signs may be required. Consult with Administration.
 - o Window is three (3) days after the 48 hours to pour, after five (5) days the notification process must be restarted. Failure to issue proper notification will result in fines.
 - o Example of sign is provided in Appendix P
 - o Communication requirement with Administration – Contractor is responsible for contacting and confirming the dates/time of anticipated concrete placements with Administration. Preferred contact method for Administration is an email; a phone call or voicemail is not acceptable. Contractor must receive an email response to confirm that contact has been made. It is the responsibility of the contractor to ensure that contact is made within the required timeline. Receipt of notice cannot be confirmed during weekends or holidays.
 - o WA State certified flaggers are required for any partial of full blockage of roads and both Security and Administration must be notified of such blockage and approximate time of said blockage.
 - o Fines will be assessed for failure to notify the defined surrounding properties.

14.7.1

14.7.2 Lot Clearing and Excavation: It is extremely important that those persons doing the work know in advance what has been agreed upon among the Committee, contractor and property owner, and that all parties are informed of any changes that deviate from the original agreement prior to commencement of excavation.

- (a) Approval of final or amended plans by the Committee shall constitute agreement among the parties as to location of the structure on the lot, number and location of trees to be removed/retained, driveway location and other site plan details. Special provisions or conditions made part of the approval shall be specified in the initial or subsequent letter of approval to the owner. **Staff must be contacted beforehand if the excavation/tree removal plan is to be altered in any way.**
 - Hazardous Tree Authority During Construction: Authority for onsite hazardous tree evaluation to be granted to the SVCA ~~Construction-Advocate~~ Maintenance & Facilities Manager and the ACC Coordinator based on the SVCA Hazardous Tree Removal SOP with the contractor/owner to replant at a ratio of 3 to 1 and new trees added to the approved landscaping plan. ~~This Authority is dependent on Advocate and Coordinator having received the proper training~~
- (b) Land-defacing and excavating shall be kept to a minimum during and after house construction or addition. Natural growth shall not be disturbed excessively or unnecessarily. IMPORTANT NOTE -- SEE SECTION 14.9.1(b).
- (c) Hauling away and/or shredding branch and stump debris is required.
- (d) No outdoor burning is allowed in Sudden Valley except as provided in SVCA Rule and Regulation Section 1.6 ~~and its sub-regulations found in the Sudden~~

~~Valley Documents.~~

- (e) Piling of dirt from excavation and rough grading during and after construction shall be done in a manner to avoid damage to trees and other natural foliage, and all such activities must be confined to the lot. **No dirt shall be piled against or beneath the drip-line of any tree.**
- (f) Encroachment by machinery or storage of materials on adjoining lots constitutes trespassing and shall not be condoned. Such cases may be subject to Notice of Violation and may be reported to the adjoining lot owner.
- (g) Care must be exercised during the clearing of trees and construction to avoid damage to vegetation on adjoining properties. In some cases, the ACC may require that the trees be removed in sections to avoid such damage. Broken branches must be properly sawn-removed back to the trunk (to the root collar) or main branch.
- ~~(h) A new pre-construction soils investigation/excavation process is proposed. This would not be part of the 12-month construction window as long as contractor complies with County requirements and returns land back to found. Minimal tree removal and replacement based on Whateom County requirements. All Tree and debris approved for removal for investigation shall be removed from site and placed in the timber storage area agreed to between SVCA and the contractors/owners. Allowance will be limited if permit is abused.~~
- ~~(h)~~ (h) Onsite equipment storage will be limited to 30 days from commencement of excavation. After such time equipment shall be removed and stored at the contractor's equipment ~~yard or at a designated location agreed to between SVCA and the contractors/owners. e.g. (Gate 5 overflow).~~

14.7.3 Erosion/Environmental Impact Control: Approved and effective silt screening devices must be placed appropriately within the job site and adjacent to any stream, lake, pond, trench, ditch or intermittent channel that drains to a flowing watercourse.

- (a) Such devices shall be composed of materials specifically designed for use in silt retention and be properly installed and maintained during construction (see Appendix E).
- (b) Straw bales, check dams, or sand-bags may be required before excavation commences and used as primary filters in addition to or in place of silt fences.
- (c) Mulch, straw, or plastic shall be used to cover areas and piles of exposed soil.
- (d) Installation of a construction entrance surfaced with quarry spall is required.
- (e) The Department of Ecology Storm Water Manual should be used for additional information and Clarity of these and other Best Management Practices (BMPs).

14.7.4 Contractor Parking: General contractors must provide temporary on-site parking for themselves and sub-contractors, and/or designate, in consultation with staff, an alternative off-site parking area. Disturbance of soil and/or vegetation shall be kept to a minimum, and off-site areas shall be restored to their pre-construction conditions prior to completing the final inspection. No on-site construction parking shall be made permanent without prior ACC approval.

14.7.5 Inspections: There are several required inspections by Administration Staff during the construction period. Following 24-hour advance notice by the property owner or their designee, staff will perform on-site inspections prior to the following stages of construction:

- (a) EROSION CONTROL - Review of erosion control measures and no-entry barriers for tree and native-growth protection to ensure they are installed properly, this includes but is not limited to:

-Silt fences and other silt screening must be installed correctly. See Appendix E for specifications.

-The root zone of all trees designated to remain must be surrounded by a no-entry barrier in accordance with Policy 14.9.1(b).

-Areas of exposed soil that will not be modified within 24 hours must be covered mulch, straw, or plastic sheeting.

-Soil piles that will not be used within 24 hours should also be covered.

-Additional materials should be available onsite to implement additional erosion control as needed or required.

No soil disturbance shall occur until this inspection has been done. Further visits by staff or administration staff to confirm proper functioning of these installations may occur at any time until completion. Erosion control and tree protection measures shall remain in place until the end of construction or when final mulch and landscape planting is complete. Failure to meet erosion control or tree protection Best Management Practices will require immediate correction and a twenty-four (24) hour re-inspection.

(b) SETBACKS - Location of the building on the site as approved by the ACC will be confirmed by an inspection when forms have been set, but prior to the pouring of concrete foundation footings. Lot boundaries and foundation wall lines must be clearly marked to allow determination of approved setbacks. Any revisions require prior ACC review and approval.

(c) ~~STORM WATER SYSTEM – Design, location, and size of the system will be confirmed by inspection after being excavated but prior to filling, covering, or enclosing. Systems may be water tested during final inspection. Consult the Administration Staff for details of the storm water system. See Appendix C for a detailed diagram.~~

(d) DRIVEWAY – Driveway configuration will be confirmed by an inspection when forms have been set but prior to pouring the driveway. Refer to section for driveway design standards and illustration for more details (see section 14.5.5). Any revisions require prior ACC review and approval. See Appendix A for more information.

(e) FINAL - Inspection for release from Committee jurisdiction will be in conjunction with Whatcom County Final Inspection and sign off and a copy provided to SVCA-Construction Advocate Architectural Control Inspector. Release will also be contingent on the owner or developer's request prior to occupancy of the structure and no later than twelve (12) months from date of start of construction, ~~per the Covenants,~~ unless an extension has been granted. ~~An automatic non-enforcement period of three (3) months will follow as an allowable variance of the regulations.~~ Extensions of time ~~beyond the non-enforcement period,~~ or other variances from this provision, must be requested in writing and approved by the ACC. Occupancy prior to final inspection will result in loss of all or part of the construction completion deposit (see section 14.7.7).

(f) TIME EXTENSIONS: Construction of a new home is expected to occur within one year from ACC approval date. Written applications are mandatory for every Extension. Failure to apply for an extension before the current permit expires will result in fines (refer to SVCA Fines & Fees Schedule).

The SVCA extension construction timeline is outlined as follows:

- Construction Permit begins on the date is issued after ACC approval is granted. The start date of the SVCA Permit is set during the compliance meeting with the Architectural Control Inspector. SVCA's REPA must also be approved before construction can begin.

- Construction is expected to complete within twelve months of the permit start date. A 1st permit extension begins exactly one year after ACC approval date. of up to six (6) months may be granted.
- Second extension begins exactly 180 days after the first extension begins. If construction will not be completed within 18 months, a 2nd permit extension of up to six (6) months may be granted.
- If construction will not be completed within 24 months, a 3rd and final permit extension of up to twelve (12) months may be granted.
- No extensions will be granted after 36 months. The project will have to resubmit for ACC approval, paying an additional new construction application fee and the original building deposit will be exhausted and a new deposit made before construction can continue.
- Failure to obtain ACC approval for a New Construction time limit extension before the current permit expires may result in a fine. An extension must be requested in writing at least one month before expiration of the current permit.
- Third extension begins exactly 360 days after the first extension begins.

SVCA extension timeline closely aligns with Whatcom County extension timeline but is not bound to it or any changes made to the Whatcom County extension schedule.

~~(e) To align with Whatcom County rules of 6 months or expiration date listed on Whatcom inspection permit, the first two (2) extensions of 6 months or expiration date listed on Whatcom inspection permit will be charged at the same rate as charged by the County, currently:~~

~~— First Extension (Post automatic 3-month period) — Free of charge~~

~~— Second Extension — \$100.00 Fee~~

~~— However, due to the restrictions of the SVCA Covenants, for the third, and any subsequent, Extensions:~~

~~- a fee of 50% of contractor/owner standing deposit will be assessed for every request.~~

(f)(g) TIMELINESS OF EXTENSION REQUESTS: Contractor/Owner shall apply for extension and receive approval from ACC before existing completion date. If after applying after existing completion date, the ACC may grant approval with assessment of fines based on existing SVCA fees and fines schedule.

~~—As a courtesy, ACC Coordinator Administration will may send out notices of time remaining on construction period or extension:~~

~~- one (1) month prior to existing completion date, and~~

~~—one (1) week prior to existing completion date.~~

Failure to receive a notice from the ACC coordinator Administration in no way removes the Contractor/Owner from responsibility for a timely request for an extension.

14.7.6 Re-Inspections: Staff will re-inspect work associated with necessary or recommended changes following initial inspection. Costs for repetition of review, without considerable progress or completion, missed appointments, or subsequent inspections due to actions of the applicant for foreseeable problems may be reasonably charged to the property owner for each re-inspection.

14.7.7 Completion of Construction/Time Limits: The construction of any single-family detached residence or addition on any platted property in Sudden Valley, the plans for which are approved by the Committee, must begin within ninety (90) days after approval, and the exterior (including exterior finish and minimum landscaping) and final inspection must be completed no later than twelve (12) months after start of construction.

~~(a) Failure to commence construction of any single-family residence within ninety~~

- (a) (90) days after ACC approval will require that the plan be re-approved by the ACC.
- (b) Consistent progress must be made throughout the construction project. The ACC shall specify to the property owner what constitutes a violation under this section and shall issue a Notice of Violation or Non-Compliance which may result in penalties and/or increased construction deposit requirements.

Failure to complete construction by the twelve (12) month deadline can result in penalties (see section 14.8.9).

14.8 CONSTRUCTION SUBMITTALS:

14.8.1 Process of Approval for Construction of an Addition or a Detached Single-Family Residence:

All construction projects undertaken in Sudden Valley are subject to Whatcom County, state and any other applicable permitting requirements. The ACC recommends that property owners contact Whatcom County for information or requirements for their specific project. For all new single-family homes, permit applications may be made with the Association and Whatcom County concurrently; however, ACC approval and verification of a Whatcom County Building Permit are required prior to construction.

Any and all member(s) delinquent in the payment of annual dues, assessments, special assessments, or any other charges associated therewith shall be suspended from all membership privileges: (a) including the ability to submit or have considered, directly or indirectly, plans, specifications, and/or details for improvements to real property, by the Committee; (b) the ability to obtain an encroachment permit to perform work within SVCA owned roads, rights of way, parks, greenbelts, or common areas (collectively the "common areas), to connect to public and private utilities such as water, sewer, etc., or to construct either temporary or permanent improvements within such common areas.

14.8.2 Construction Application: All documents shall be submitted in electronic pdf form in addition to the standard paper submissions. The following items shall be submitted and/or completed at time of application:

- SVCA Construction Application and Checklist **shall be signed by property owner**
- Application fee (see section 14.8.8)
- Copy of survey by a licensed surveyor including topography, trees, and square footage (see section 14.8.10)
- ~~Two (2)~~ One (1) set-sets of construction plans (including floor plan, elevations, and finished grade)
- ~~Two (2)~~ One (1) copy-copies of site plan @ 1"=10' scale (see Appendix I for sample)
- ~~Two (2) copies~~ One (1) copy of landscaping plan @ 1"=10' scale
- Driveway cross-section, showing road edge to garage slab
- One (1) copy of specification sheet including paint chips, roof color, lighting sample
- Proof of insurance shall be provided for general aggregate liability coverage (see section 14.4.1)
- One (1) copy of water/sewer availability
- Property and building corners must be staked as described in section 14.8.11.
- ALL trees requested for removal must be clearly ribboned and indicated on site plan
- Written application for variance, if any
- A refundable Completion Deposit is due during permit-compliance review meeting - see section 14.8.9

14.8.3 Preliminary Review: To help property owners and potential property owners in Sudden

Valley avoid unnecessary expenses, the ACC will consider partial submittals for unusual or questionable projects (see section 14.8.13). These submittals would be for approval “in concept only” and a complete submittal would be required prior to final approval being granted. Any approval of these submittals is non-binding.

14.8.4 Submittal Deadline and Completeness: Plans submitted to the Committee for consideration must be complete as to the content specified below and must be received at least ten (10) working days (excluding holidays) prior to the scheduled meeting of the Committee at which the request is to be considered. A submittal meeting must be scheduled with the Administration Staff.

14.8.5 Other Submittal Requirements: Any individual or company making application for new construction, repair or substantial remodeling within Sudden Valley shall provide to the ACC:

- (a) A current and valid State of Washington General Contractor's license, unless owner-built for owner use in accordance with exceptions to state licensing requirements (see section ~~13~~14.4).

Certificate of Insurance evidencing general liability coverage of at least one million dollars (\$1,000,000). Additions are required to have coverage of at least five hundred thousand dollars (\$500,000).

ACC Compliance Review and Disposition: Whatcom County and SVCA permits are required for all construction activity in Sudden Valley. Both Whatcom County and Sudden Valley approved plan sets and permits must be consulted during construction to ensure compliance to all regulations and permit conditions. Failure to obtain SVCA authorization to proceed prior to commencement of construction will result in issuance of a Stop Work Order and Notice of Violation to the owner. The Committee shall approve or disapprove accepted plans, specifications and details within thirty (30) days from receipt thereof or shall notify the person submitting them when an additional period of time, not to exceed an additional thirty (30) days, is required for such approval or disapproval. ~~Plans, specifications and details with written Committee approval or disapproval, shall be returned to the person submitting them. At least one~~

14.8.6 ~~(1) copy~~ Plans submitted shall be retained by the Association.

14.8.614.8.7 Quality and Content of Submittals: The Committee requires a series of plans and forms to determine if the building project meets all of the Sudden Valley Covenants and Policies. All of these plans and forms must be submitted in the detail required for the building application to be considered. Building documents submitted to the Committee for approval shall be accurate, near as possible to "professional quality" and shall include:

- (a) ~~Existing Conditions~~ **Site Plan** using 1-inch = 10-foot scale depicting:
- The SVCA division, lot and **street address**;
 - Property boundaries including the road right-of-way;
 - Location of the proposed structure on the lot showing roof line (solid) and wall lines (dashed);
 - Proposed setbacks from the property boundaries to **eaves**;
 - Proposed location of walks, decks, patios, and driveway;
 - Proposed location of any turn-around and/or permanent, non-driveway parking (such as may be desired for inclement weather conditions).
 - Accurate location of all trees (six (6)-inch diameter or larger) on lot indicating species and size.
 - Trees that the developer proposes to remove should be so designated;
 - Rock outcroppings or other major geological features;
 - Abutting wall line of existing homes on adjacent lots;
 - Location of water courses, natural drainage areas and standing water;

- Existing lot contour lines shown at two (2) foot vertical intervals;
See Appendix I for a sample site plan.

(b) ~~Proposed Construction and Landscaping Site Plan:~~ using 1-inch = 10-foot scale depicting:

- The SVCA division, lot and **street address**;
- Property boundaries including the road right-of-way;
- Location of the proposed structure on the lot showing roof line (solid) and wall lines (dashed);
- Proposed setbacks from the property boundaries to eaves;
- Proposed finish grade at each wall (expressed as ft. in elevation, consistent with topography);
- Proposed elevation of garage floor (expressed as ft. in elevation, consistent with topography);
- Proposed finished grade contour lines shown at two (2) foot vertical intervals;
- Proposed location and composition of walks, decks, patios and driveway;
- Proposed location and composition of turn-around and permanent, non- driveway parking
- Location and details of proposed retaining structures;
- Location of all proposed outdoor lighting; Proposed location of utilities;
- Proposed location of accessory structures;
- Proposed location and screening details for propane tanks and trash receptacles;
- Proposed location of storm water retention system, main sump and clean-out (see sec. 14.6.5);
- Locations of water courses and natural drainage areas;
- Proposed placement and description of plant materials, rock, fencing, etc. (see section 14.9);
- Proposed landscaping changes within the road right-of-way shall be included in the plan.

(c) Elevations Drawings using 1/4-inch = 1 foot scale depicting:

- Proposed structure location on the lot, two (2) cross sections may be required on complex slopes;
- Scaled cross section elevations of proposed retaining structures;
- Scaled cross section drawings of the lot and road right-of-way depicting the slope.

(d) Typical Exterior Building Sections using 1/4-inch = 1 foot scale depicting:

- All sides of the structure sufficient in detail to show accurate depiction of construction and materials.
- Proposed finish grade at each wall (expressed as feet in elevation).

(e) Floor Plans for all interior living space using 1/4-inch = 1 foot scale.

(f) Roofing Layout Plan using 1/4-inch = 1 foot scale.

(g) Driveway Cross Section: using 1-inch = 10-foot scale depicting:

- Driveway from the road edge to the garage slab with degree of slope indicated

(h) Variance Request as may be applicable, in writing.

(i) SVCA Application and Checklist Forms completed with signed statement that documents site preparation are sufficient to allow adequate review by the Committee.

14.8.7/14.8.8 Submittal Application Fees: ~~A fee based on the total square footage of both finished and unfinished living space~~ Payment of the required submittal fee shall accompany the submittal of plans for new single-family detached structures and additions. If the additional square footage of an addition project is equal to or greater than the existing structure it will be considered a new home construction project, subject to applicable fee and deposit requirements. Except as stated below, no

additional fee shall be required for re- submittal of plans revised in accordance with Committee requirements or recommendations. Any approval for which an extension beyond the 90-day start of construction deadline has been properly obtained, the work on which has not been commenced within one (1) year from the original approval date, shall be considered void. Such plans shall require complete re- application along with the appropriate fees.

<u>Living Space Square Footage</u>	<u>Type of Submission</u>	<u>FEE</u>
1,000 (min.) and up	<u>New Construction</u>	Contact Administration
	Additions (smaller than existing home)	Contact Administration about fee for additional sq. ft. space

- Refundable new construction completion deposit: Contact Administration
~~Administration (see sect. 14.8.9).~~
- Refundable addition/remodel/completion deposit: Contact Administration ~~and/or variable deposit based on scope and complexity of project (see section 14.8.9).~~
- Fees paid for plans permanently withdrawn prior to Committee action are refundable up to eighty percent (80%).
- Sudden Valley Tier Structure for Residence Additions and Structural Changes see Appendix N.

~~14.8.8~~**14.8.9 Completion Deposit:** A completion deposit is required for new home construction projects in an amount to be set by the SVCA Board. For deposit amount for additions to existing homes contact Administration. Deposit is payable by the property owner or authorized agent upon plan approval prior to start of construction. In the event the project is completed in a timely manner as evidenced by Sudden Valley final inspection and the property owner has complied with all applicable requirements and procedures, the SVCA, upon written request from the property owner, shall promptly return the completion deposit and release the project from Committee jurisdiction.

- (a) The deposit shall be for the purpose of ensuring that all sums that may become due to SVCA between the date of issuance of a construction permit and the issuance of a certificate of completion are paid in full.
- (b) Deposit may be increased for individuals, either owner or contractor, who have exhibited a record of flagrant and/or consistent rules violation.
- (c) Non-compliance within the ACC approved time limit, non-approved changes, un-repaired damage to Sudden Valley property, **occupancy without final inspection** or failure to pay any outstanding fines related to the project may result in the total or partial forfeiture of the deposit.
- (d) At the discretion of the SVCA Board, amounts forfeited under the completion deposit provision may be used to rectify problems on the site to the extent allowed by law but shall not be considered liquidated damages.

~~14.8.9~~**14.8.10 Survey Requirements:** The Committee will require that the site plan as submitted reflect the results of an accurate survey. Therefore, prior to plan submittal, it shall be the responsibility of the developer or his/her designee, to have a licensed surveyor accurately locate the property corners, determine square footage of the lot, map contour lines for the lot at two (2) foot vertical intervals and accurately locate all trees (six (6)-inch diameter or larger) on the lot indicating species and size.

- (a) Staff shall determine the adequacy of survey information during the pre-meeting site review. Survey stakes shall not be disturbed unnecessarily during construction.
- (b) Stakes that are buried or otherwise obliterated shall be reestablished at the owner's expense by a **licensed surveyor** upon completion and prior to final inspection.
- (c) Due to Sudden Valley's location in the Lake Whatcom Watershed, it is advised that physical characteristics of the site be reviewed to identify environmentally sensitive areas, such as streams, wetlands, forests, and wildlife features. If any are found, the applicant should contact Whatcom County immediately to discuss any potential buffers or restrictions.

~~14.8.10~~**14.8.11 Pre-Meeting Site Preparation:** For inspection prior to the Committee meeting at which the project is to be considered, **corners of the proposed structure (including eaves) shall be staked and roof lines indicated with string**; roof corners in one color and decks in a different color. ALL trees designated for removal shall be marked on site using surveyors' tape (NOT spray paint) and shall be consistent with those noted on the site plan submitted. Such preparation must be completed at time of submittal.

~~14.8.11~~**14.8.12 Utility Locate:** Prior to excavation, a utility notification center must be contacted.

~~14.8.12~~**14.8.13 Variances:** It is realized that, with the passage of time, these policies may change in keeping with updated building materials technology, methods of

construction and style or architectural concepts.

The Committee may allow reasonable variances and adjustments of these restrictions in order to overcome practical difficulties and to prevent unnecessary hardships in the application of the provisions contained herein; provided that such is done in conformity with the intent and purposes hereof and that in every instance such variances or adjustments will not be materially detrimental nor injurious to other properties or improvements in the neighborhood, the unit or subdivision (see section 14.8.3).

- (a) Requests for a variance must be made in writing to the ACC.
- ~~(a)(b)~~ Any stand-alone variances approved by the Committee prior to submittal of a complete application shall expire 180 days after the date of approval.

149 - LANDSCAPING: Landscaping alters the appearance of a property and requires prior ACC approval. Because well designed and maintained landscaping increases both individual and community property values, the Committee requires certain minimum landscaping standards for all developed property in Sudden Valley. These policies attempt to integrate the aesthetics of the site with the natural environment, protect native features, and provide for adequate soil stability. The SVCA shall specify to the resident what constitutes a violation under this section and shall issue a Notice of Violation or Non- Compliance in accordance with the Covenants, Rules and Regulations and these Policies. Any proposed landscaping that requires tree removal, significant removal of native vegetation, re-shaping or grading of soil, retaining walls, etc. require prior ACC approval. Landscape plans are considered on an individual basis and their approval/disapproval shall not be based on any previous approval or pre-existing landscape plan.

14.9.1 Landscape Policy:

- (a) ~~Existing SVCA encourages the planting of native vegetation shall be utilized to the greatest extent possible when formulating the landscape plan (provided it is healthy and suitable for the site). Buildings, driveways and parking areas shall be planned or arranged to provide for a minimum removal of such vegetation both on the lot and in road right-of-ways.~~
- (b) Preserved trees on the lot and in the road right-of-way shall be protected from damaging construction activities by placement of no-entry barriers around the tree ~~at the drip line protection zones.~~ For every inch of trunk diameter (diameter at breast height, DBH), extend protection by one (1) foot in radius, or to the drip line, whichever is less. Tree protective fencing shall be a minimum height of three feet, visible, and of durable construction; orange polyethylene laminar fencing is acceptable; and signs must be posted on the fence reading "Tree Protection Area." Other tree protection may be requested by the ACC for more vulnerable trees. Owners may be fined for unauthorized tree limbing/removal when trees are 14.9.1(damaged or destroyed by such activities and where there is sufficient evidence of negligence in protecting such trees (see section 14.10). Any significant trees identified in a landscape plan to be retained, and subsequently damaged or removed during site development shall be replaced at a rate of three trees for each one damaged or removed. Replacement coniferous trees shall be at least eight feet in height; replacement deciduous trees shall be at least two and one-half inches in diameter (DBH), and shall be species native to western Washington. Installation, maintenance, and care of required replacement trees shall be in accordance with the International Society of Arboriculture's best management practices for arboriculture including, but not limited to, soil

assessment, sampling, amendments and conservation, and spacing, which ensure the tree's long-term health and survival. Replacement trees shall not be topped or otherwise be prohibited from their natural growth.

- (c) All cuts and fill slopes on developed lots greater than 2:1 (horizontal/vertical) in slope that are judged by staff or the ACC to be unstable, whether they are pre-existing, created by driveway cuts or other general lot excavation, must be corrected by the construction of retaining walls or grading plans meeting the approval of the Committee. Cuts and fill slopes of less than 2:1 (H: V) shall, at the minimum, require matting and planting with suitable materials or employment of other methods to maintain soils in place and such erosion prevention measures shall be used throughout construction (see section 14.7.2).
- (d) Retaining walls shall be composed of materials that are consistent or harmonious with other site elements and the residence. Cinderblock walls and plain concrete walls (non-exposed aggregate type) will not be approved without the inclusion of wood screening or vegetation. Other structures shall be built using materials that are rated, graded or stamped for use in contact with the ground.
- (e) All construction and landscaping debris, slash, removed stumps, brush and trees must be removed from the lot. That which is usable (i.e. firewood) shall be neatly stacked and stored. No landscape debris may be dumped anywhere within Association property.
- (f) All disturbed soils must be graded, smoothed and compacted where necessary to prevent erosion. Bare earth must be seeded, covered with mulch or planted with trees or ground covering plants in order to counteract erosion and provide for aesthetics.
- (g) To enhance groundwater infiltration, plastic under landscaped surfaces is prohibited. Only porous landscape fabrics or specialized matting materials may be utilized. The use of ground rubber mulch is prohibited.

On sites where ~~the majority of~~ mature native trees require removal for even minimum construction, such trees may be required to be replaced by a tree(s) at a suitable location upon the lot, and the replacement of such trees may be required by the Committee as a condition of approval for the home submittal. Replacement coniferous trees shall be at least eight (8) feet in height; replacement deciduous trees shall be at least two and a half (2.5) inches in diameter (DBH).

- (i) Treated timbers or other suitable edging shall be placed along crushed rock driveways to define access and parking areas and to contain and minimize the scattering of rock. Timbers treated with creosote are not permitted.
- (j) Any proposed landscaping that extends into the road right-of-way shall be done at the property owners' risk and if approved by the Committee, shall be maintained by the property owner. Road right-of-way remain SVCA property and use of such right-of-way shall remain available for any SVCA member. Improvements may be removed without notice by SVCA for access to utilities, etc. In addition, SVCA may require an encroachment agreement.
- (k) Residents shall abide by noxious weed laws (RCW 10.17 and WAC 16-752) and exercise care not to introduce noxious or invasive weeds into Sudden Valley. A list of noxious and invasive plants can be found online.

~~or by contacting the Administration Staff. (see Appendix XXX)~~

- ~~(f) Residents are encouraged to make every effort to use the community garden in Area Z, instead of individual vegetable gardens. However, individual vegetable gardens may be permitted with prior ACC approval.~~

14.9.2 Landscape Plan Submittal: Any proposed landscaping that requires tree removal, significant removal of native vegetation, re-shaping or grading of soil, retaining walls, etc. requires prior ACC approval. Landscape plans are considered on an individual basis and their approval/disapproval shall not be based on any previous approval or pre-existing landscape plan. Submittal shall include the following information:

- (a) Application with name, date, division/lot, street/ mailing address, phone number.
- (b) Submittal of a site plan including:
 - Location of all structures, driveway, trees, etc.
 - Trees proposed for removal clearly identified (see Section 14.10).
 - Location and dimensions of retaining walls.
 - Proposed landscaped areas clearly marked.
 - Proposed changes within road right-of-way.
- (c) Narrative describing landscape proposal including tree, vegetation and material descriptions, drainage concerns and any additional considerations you would like the Committee to consider.
- (d) If landscaping is not completed within six (6) months of approval, applicant shall resubmit the request to Committee.

1410 - TREE REMOVAL AND LIMBING: Protection and preservation of property values may be accomplished by appropriate control of growth of trees, shrubs and naturally occurring vegetation; however, such actions shall be weighed against preservation of wildlife, protection of soil stability, water quality and related aspects of drainage, and adherence to the overall concept of Sudden Valley, which includes protection of the natural forested beauty of the area and taking fire preventive measures into account. For additional Firewise information, see Appendix K.

Within an individual's clearly marked property boundaries, routine maintenance can be performed and is encouraged without ACC approval. This includes conversion of lawns to naturalized landscaping, maintenance of plantings, removal of undesirable landscape and non-native trees and shrubs, removal of dead branches and pruning of tree branches where appropriate that are 6 inches or less in diameter. Removal of branches may not exceed 30% of the foliage density of any individual specimen without written approval of the ACC. To provide adequate air circulation and mitigate fire risk; small trees, branches and vegetation within 10 feet of a residential structure may be removed without ACC approval. Large conifers growing in this 10-foot buffer, with a diameter of 10 inches or greater may only be removed with prior ACC approval, and debris must be removed immediately.

To provide room for growth, light and nutrients to more mature conifers and native evergreens, trees can be limbed or windowed according to the Washington Department of Ecology guidelines (see Appendix K) with ACC approval.

14.10.1 Tree Removal and Limbing Criteria: Many criteria are used in evaluating requests for tree removals or limbing. These include, among others:

- (a) Immediate safety concerns including trunk and/or branch failure potential.

- (b) Fire prevention and lack of air circulation from trees overhanging roofs, near chimneys or structures.
- (c) Future safety concerns such as retaining a solitary tree in a cleared area (orphan) or retaining a leaning or oddly shaped tree on the edge of a cleared area or next to a roadway.
- (d) Encroachments where trunk, branches or roots would be or are in contact with main or accessory structure(s) or where utilities would unavoidably cut through root system.
- (e) Health of the tree and/or those adjacent where there are obvious signs of infestation, incurable disease or stress that likely would lead to early or premature death or trunk/root failure.
- (f) Maintenance of property values where vegetation has been allowed to grow unchecked and now poses aesthetic concerns for neighbors.
- (g) Creation or maintenance of view corridors (vertical and/or horizontal) where vegetation has grown unchecked and now obstructs views once enjoyed by the lot owner or neighboring lot owners.
- (h) Consideration of privacy concerns where a request is made to remove or limb a tree that might substantially reduce existing and highly valued screening between neighboring properties.
- (i) Prevailing wind direction.
- (j) Specific characteristics of different tree species.
- (k) Maturity, health and growth potential of existing trees and vegetation in the surrounding environment.
- (l) Soil stability and potential erosion.
- (m) Protection and preservation of property values.

14.10.2 Tree Removal and Limbing Submittal: Except where provided above, all proposed tree removal or limbing requires prior ACC approval. Proposed tree removal and limbing requests are considered on an individual basis. Application forms are available from the SVCA administration office or SVCA website: www.suddenvalley.com (under forms). Tree removal and limbing applications will be considered by the Committee subject to the following:

- (a) Applications to include the property owner's name, submittal date, division/lot, **street address**, mailing address and contact phone number.
- (b) Submittal of a clearly marked site plan depicting the following:
Location of all existing structures, driveway, property lines, significant landscaping, etc. Trees proposed for limbing or removal clearly identified.

To allow neighbors notice whenever tree removals or limbing might affect them directly, trees to be limbed or removed must be clearly ribboned. Ribbons must be brightly colored and wrapped fully around the tree's trunk at eye level for at least one (1) week in advance of the ACC meeting except in cases of hazard trees which can be dealt with on an emergency basis. For requests involving more than one tree, ribbons shall be numbered corresponding to the numbering on the request diagram. Trees not appropriately ribboned will not be reviewed by the ACC. **(Spray paint or any other permanent marking or flagging is prohibited)**
- (c) **Narrative Description:** Reasons for the removal or limbing and any additional considerations you would like the Committee to consider.
- (d) If the tree removal or limbing is to occur on a lot not belonging to the applicant, written consent of the owner(s) is required prior to submission of the request. Unless otherwise specified, removal of debris will be the responsibility of the applicant requesting the limbing/removal.
- (e) It is important that persons doing the work know in advance what has been agreed

upon between the Committee and property owner, and that all parties are informed of any changes that deviate from the original request and/or agreement prior to commencement of any tree pruning or removal.

- (f) If action is not completed within one (1) year of receiving permit, applicant shall resubmit the request to the Administration Staff for review and re-approval.

14.10.3 Tree Removal and Limbing - General Practices and Policies:

- (a) Care must be exercised during clearing of trees to avoid damage to surrounding vegetation. In some cases, the ACC may require that trees be removed in sections to avoid such damage. Broken branches on adjoining trees must be properly cut back to the main lateral or “parent” branch or the trunk’s branch collar if appropriate, with prior approval from the Committee.
- (b) If trees are to be climbed to complete approved limbing, climbing spurs should only be used when absolutely necessary.
- (c) To increase safety for pedestrians, bikers and drivers and to maintain clear lines of sight along both sides of the roadside, branches and vegetation shall be removed as determined by SVCA staff. Wood acquired by the Sudden Valley Maintenance Department may be available to residents, either on the site or at designated areas such as the ~~community garden~~ [Area Z woodcutting site](#).
- (d) Requests to remove vegetation in wetlands or other environmentally sensitive areas may require approval from Whatcom County as well as from the Committee.
- (e) The ACC shall have the authority to approve or disapprove tree removal/limbing requests on commercial and condominium tracts and platted lots. SVCA staff shall make determinations for trees on the right-of-way and common areas.
- (f) Authorization from the Administration Staff must be received prior to the mechanical clearing of any property in Sudden Valley.
- (g) A tree request denied by the ACC may be reconsidered if the applicant provides the Committee with a written report, including an executive summary of recommended actions, from an ISA-certified arborist. A list of available local resources may be obtained from the Administration.

14.10.4 Pruning Conifers: Skirting-up, Interlimbing, Windowing (WA. Dept. of Ecology—see Appendix K). All debris must be removed immediately.

Skirting-up. Limbing the tree up from the bottom allows a clear line of sight. Relatively more branches can be removed with this technique because the lower branches contribute fewer nutrients to the tree than the higher branches.

Interlimbing. The removal of entire branch whorls or individual branches throughout the canopy allows more light to pass through, as well as reducing wind resistance of the tree. This practice can be used in conjunction with windowing to improve views. **Windowing.** This pruning practice allows a view “window” through the existing foliage of the tree’s canopy. In pruning major limbs and branch whorls, sections that obscure a view are removed. This practice should be minimized as it can impose significant stress on mature trees.

Topping. Topping of trees is strongly discouraged in Sudden Valley. Topping and windowing of trees is prohibited on SVCA owned property, as it has been recognized by the International Society of Arborists (ISA) as injurious to the health of the tree. SVCA will utilize alternative remedies and practices to address tree limbing and maintenance, following ISA Best Management Practices for appropriate techniques and procedures. (If homeowners wish to utilize these practices for their own trees, the ISA guidelines will be available from the Administration).

14.10.5 Emergency Hazardous Tree Removal ~~(Approved 5/15/14)~~

The Whatcom County Planning Department defines a hazard tree as “any tree that

is susceptible to immediate fall due to its condition (damaged, diseased, or dead) or other factors, and which because of its location is at risk of damaging permanent physical improvements to property or causing personal injury.” (Whatcom County, Planning Department, (2009) Section 23.110.080).

If a property owner’s tree begins to fail due to severe weather or other natural disasters and a fall is imminent, it can be removed on an emergency basis if the stump is left in the ground and photographs and a description of the circumstances are submitted to the ACC as soon as possible.

If a property owner desires to have a tree on SVCA property removed or limbed, an application shall be submitted to Administration using the same form used for all tree requests. The purpose for the removal shall be clearly stated; for example, a hazardous tree, sight line restoration or improvement, etc.

Upon receipt of the application, Administration shall refer the issue to the Maintenance & Facilities Manager, who shall investigate the request and report to the ACC. The ACC shall prepare a recommendation for the consideration of the Board of Directors. The Committee evaluation shall include recommendations concerning the advisability of the requested action and the party responsible for the expense of the action. In the event the tree is located on golf course property, the opinions of the Golf Course Superintendent, Golf Director, and General Manager shall be included in the Committee report.

Only SVCA employees or licensed and bonded tree service personnel shall be permitted to perform such actions on SVCA property.

The Board of Directors may direct the replacement of any removed tree.

1411 - PROPERTY MAINTENANCE: The SVCA shall specify to the resident what constitutes a violation under this section and shall issue a Notice of Violation or Non-Compliance in accordance with the Covenants, Rules and Regulations and these Policies. Basic maintenance of developed property such as repair or replacement of existing approved exterior elements on a like-for-like basis and re-staining or re-painting with existing colors may be ~~performed without committee or staff review~~ approved by the General Manager without the need for Committee review.

14.11.1 Developed Property: All developed property, whether occupied or unoccupied, and all improvements (buildings, accessory structures, fences, etc.) and landscaping shall at all times be maintained in such a manner as to prevent their becoming unsightly due, but not limited to: deteriorating exterior materials and finish(es) (siding, roofing, decks, paint, etc.), unchecked growth of common or invasive weeds, accumulation of rubbish (i.e.- household garbage, recyclables, pet waste, oil/gas cans, palettes), improper outside storage (i.e.- ladders, lawn equipment, automotive parts, play equipment), or brightly colored tarps and coverings.

14.11.2 Tree and Brush Maintenance: All property owners shall be responsible for the removal and clean-up of dead or hazardous trees, limbs and dead brush on their property(see section 14.10). Spread of fire, especially on undeveloped lots, is a significant danger.

14.11.3 Storm Water Control: Gutters, downspouts, driveway strip drains, and the storm water retention system shall be maintained so as to function correctly. The storm water retention system cleanout should be emptied of debris at least annually (see

section 14.5.8).

14.11.4 Street Address: The street address shall be kept clearly visible for all developed property within Sudden Valley (see section 15.2).

Exterior Storage: All outside storage areas must be screened from view of adjacent properties and roads. This includes areas for storage of trash and recycling containers, under decks where such areas are used to store any type of materials, or any area on the lot where materials are being stored.

14.11.5 Replacement of Damaged Structures: No improvement which has been substantially or totally destroyed by fire, earthquake, wind damage, or other means shall be allowed to remain in such state beyond the minimum time period necessary to secure inspections and permits allowing removal of the debris or to begin repair of the structure. In no event shall this period exceed four (4) months from the date of such destruction or loss unless it can be shown that such delay is beyond the control of the owner. If a damaged structure is to be rebuilt or replaced, all requirements for approval of plans by the Committee, time limits for completion and other rules as specified elsewhere in these Policies shall apply.

15. POLICIES FOR SIGNS ON PLATTED LOTS:

15.1 GENERAL: One (1) permanent identification sign shall be permitted on each lot, not more than one (1) square foot in size, stained a natural color with wooden or metal letters or numbers that may depict the name of the owner and the street address. **Signs may NOT be attached to trees.**

15.1.1 For the Purpose of these Policies, the term "Sign" shall mean and include any exterior or visible from the exterior, written or pictorial message intended to be read or observed by others, from adjacent lots, parcels or roads. Home security warnings and decorative yard placards not exceeding one square foot in area shall be permitted and shall not be considered to be signs.

15.2 ADDRESS: All homes shall have street address numbers that are visible from the main street. These numbers shall contrast with their background, be Arabic numerals and/or alphabetical letters, and be a minimum of 5 inches high. Address numbers shall be posted on the structure unless the structure is not visible from the street, in which case a monument, pole, or other means, subject to prior Committee approval, shall be placed adjacent to the access to identify the structure. In no case shall numbers be attached to trees.

15.3 FOR SALE AND FOR RENT SIGNAGE: Sudden Valley owners wishing to display their Homes or Lots for sale or their homes for rent may do so provided that the sign is 8 ½ by 14 and is in the format of Exhibit "M" and as described below (see section 15.3.1) and is posted in full view on each property. Other information materials may be placed outside the residence provided it is contained within an approximate 9" by 12" plastic box equivalent to the IDC Inc. "Info Center." Specific Realty Company signs i.e.: ReMax, Coldwell Banker, etc. are not allowed in Sudden Valley. Signage may be obtained from Sudden Valley staff for a nominal fee. **Absolutely no Signage** shall be attached to trees or vegetation.

1531 - Signs may be purchased from the SVCA Administration office that display the Sudden Valley logo, list the Division and Lot number, the name of the property owner or contact person (if desired), and a telephone number. These signs may be posted no closer than five (5) feet from the edge of the asphalt of an adjoining SVCA road.

1532 - Owners of multiple lots for sale may contract for the manufacture of such signs, rather than ordering them from the SVCA, provided such signs are in accordance with Exhibit M are accurate facsimiles in terms of size, coloring, logo and lettering. Owners or

agents may reuse signs by changing the information, provided that the lettering is consistent in style, color and size with those produced by SVCA.

15.4 **OPEN HOUSE SIGNS:** Portable open house signs may be placed to direct people to a particular home for sale. Only one (1) such sign for each open house shall be permitted at any one (1) street intersection. The owner(s) or qualified sales agent must be present at the open house during any period when such signs are in place.

CONSTRUCTION SIGNS: Prior to commencement of and during any New Construction, addition or major landscaping, a sign per Appendix L, not to exceed 8 ½ by 14 inches in size shall be placed on the property where the work is being performed. The sign shall contain all pertinent information illustrated by Appendix L and shall be of a style and character that does not diminish the aesthetics of the surrounding area as determined by the Committee. Signs may be obtained from the Sudden Valley office after ACC grants approval for the project. The sign shall be placed facing the road in plain view, no nearer than five (5) feet and no further away than ten (10) feet from the paved surface. The sign must be removed from the site within ten² (10) days following completion of the work and/or final inspection of the structure by the Administration Staff. The property owner may be subject to fines for failure to place the sign during the approved work period and or remove any sign following the ten (10) day period at completion. **Signs may not be attached to trees or vegetation.**

15.5 **OTHER SIGNS:** Permission must be obtained from SVCA Security prior to posting any type of temporary flyer, including garage sale or directional signs. Where specifically permitted, such signs may not be affixed to trees or to traffic signs and may not be posted prior to the day of the sale or event and must be removed promptly (the same day) after the sale or event concludes. Signs may not be attached to trees.

15.6 **DISPLAY OF POLITICAL SIGNS:** Political signs which are defined as signs supporting or opposing any candidate, proposition, measure or resolution to be voted on at a special or annual meeting of the SVCA or primary or general municipal, state or national election may be displayed within Sudden Valley Community Association as follows:

1561 Period of Display: Political signs may be displayed no more than 45 days before the election to which they refer and shall be removed within 48 hours after the election.

1562 Display of Political Signs: Maximum size for any such sign is 18"X 24" with an aggregate total area of no more than 18 square feet per lot. Signs may not be lighted, animated in any way or adorned with reflective ribbons, streamers, banners, balloons, or similar devices to attract attention.

1563 Location of Political Signs: Political signs may be placed only on the owner's private lot. Signs may not be placed on Association property, the property of others, or within the road right-of-way. Signs must not be placed in such a manner as to create a vision restriction for persons entering or leaving a driveway or traveling on Association roadways.

1564 Removal of Signs: Any signs placed within the Association's road right-of-way or on Association property will be removed and disposed of without notice.

15.7 **DISPLAY OF THE AMERICAN FLAG:** The display of the American Flag shall be permitted in accordance with State and Federal law (RCW 64.38.033 and the Freedom to Display the American Flag Act of 2005). Any display of the American flag in conjunction with any lettering, symbol, object, or depiction of a person shall be deemed to be a political sign and shall be regulated as such. The installation of a flag pole is considered an exterior alteration and must be submitted for approval to the Committee.

15.8 **PENALTIES FOR SIGN RULE VIOLATIONS:** Violation of the sign rules of the Sudden Valley Community Association shall be subject to the current fineschedule

- 16. ENFORCEMENT:** For information about enforcement, please contact Sudden Valley Community Association Administration Staff.
- 17. FINES:** For information about fines, please contact Sudden Valley Community Association Administration Staff.

APPENDIX A

Driveway and Culvert Specifications

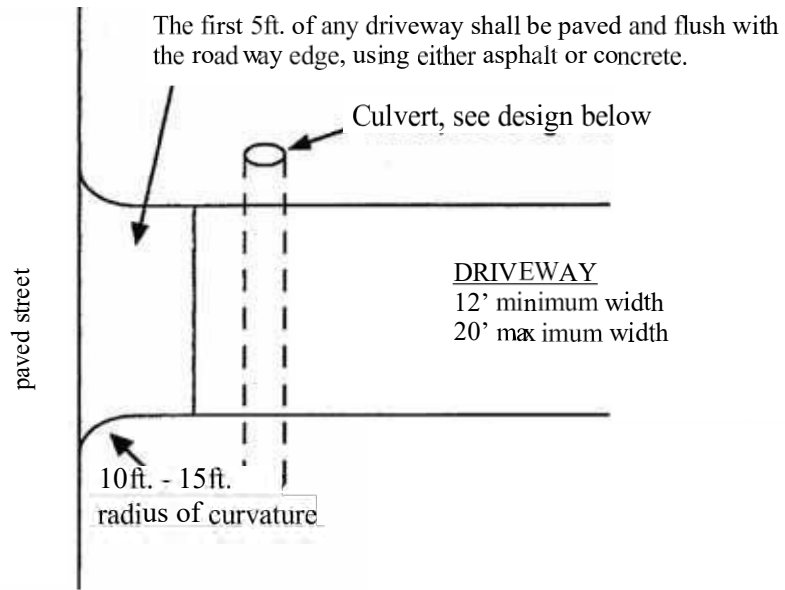

Driveway to pavement edge in terrace to be straight cut or permanent asphalt patched.

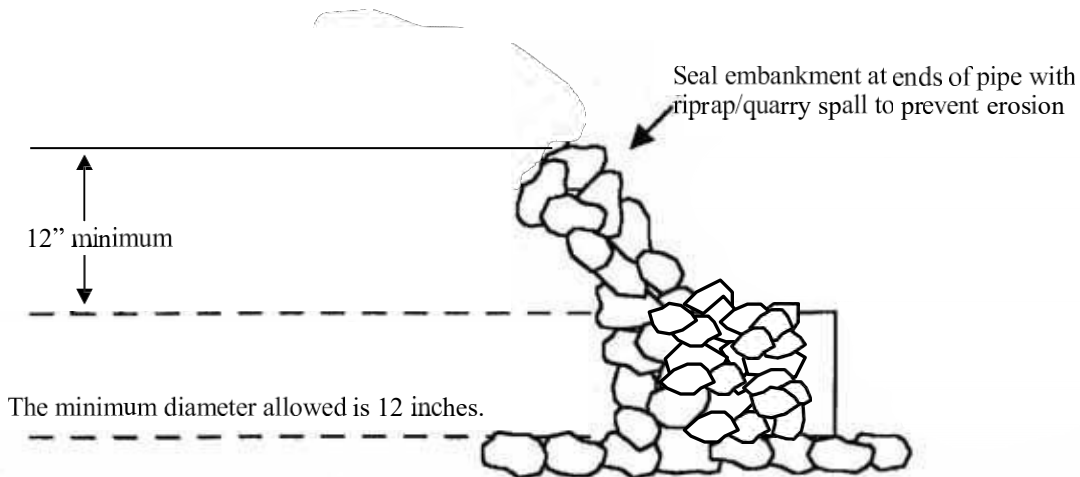
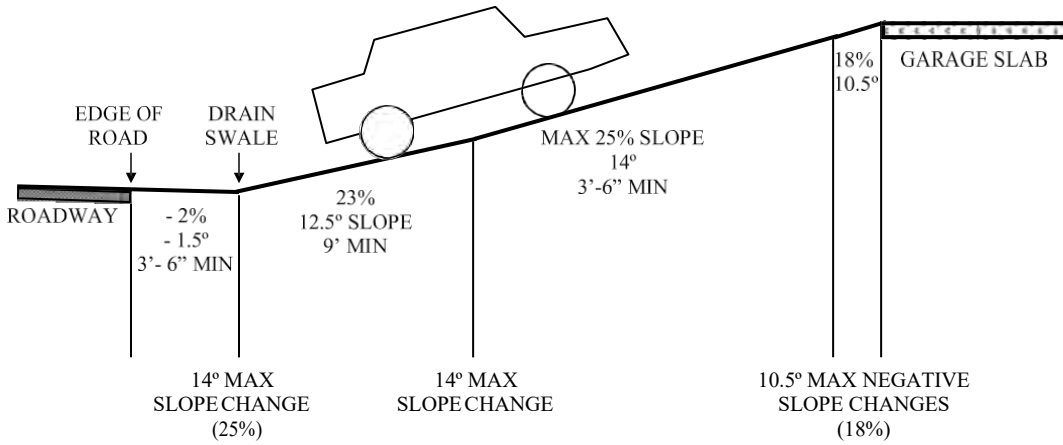

A concrete catch basin, Type 1 with a clean-out, shall be installed per each 40 lineal feet of culvert installed AND/OR at a change in culvert horizontal and/or vertical alignment.

APPENDIX B

Height Regulations and Definitions

Height Regulations: Maximum structure height in Divisions one (1) through thirty-four (34) shall be thirty (30) feet under Definition I or twenty (20) feet under Definition II (see section 14.6.2). Height limitations for later platted divisions may vary according to the covenants for that specific division. The owner, upon application, may elect either height definition, but structures shall not exceed the height limits as specified.

Definition I - The vertical distance from the finished grade to the highest point of the coping of a flat roof or the peak of the highest gable of the pitch or hip roof.

Finished Grade: The lowest point of the finished surface of the ground, paving, or sidewalk within the area between the wall of the building and property line or, when the property line is more than five (5) feet from the wall of the building, between the wall of the building and a line five (5) feet out from the wall of the building.

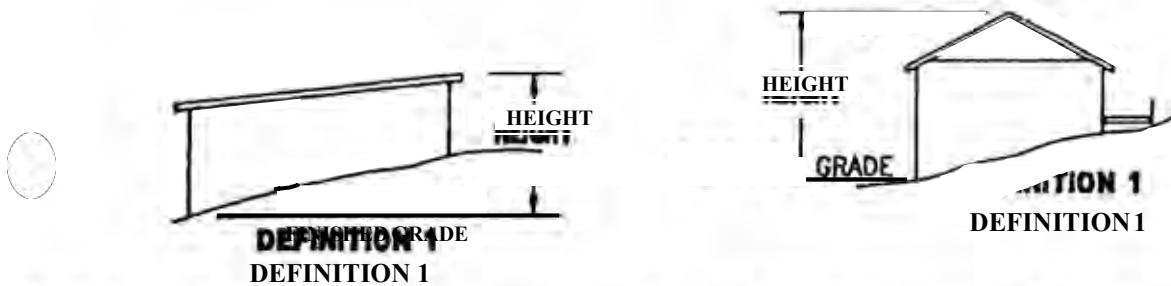

Definition II - The vertical distance measured from the highest point of the finished grade within the building site to the highest point of the coping of a flat roof or the peak of the highest gable of the pitch or hip roof.

Building Site: The area surrounding the exterior wall of the structure extending a distance of ten (10) feet from the wall, except when the structure is less than ten (10) feet from the lot line, in which event the lot line shall define the edge of the building site.

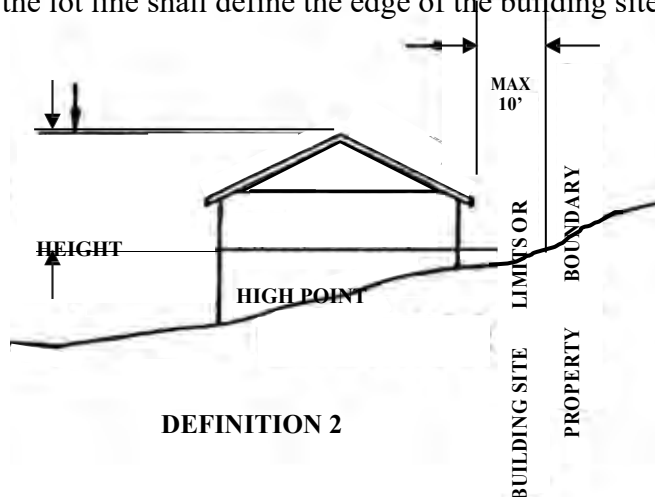

APPENDIX C

Storm Water Retention System Design

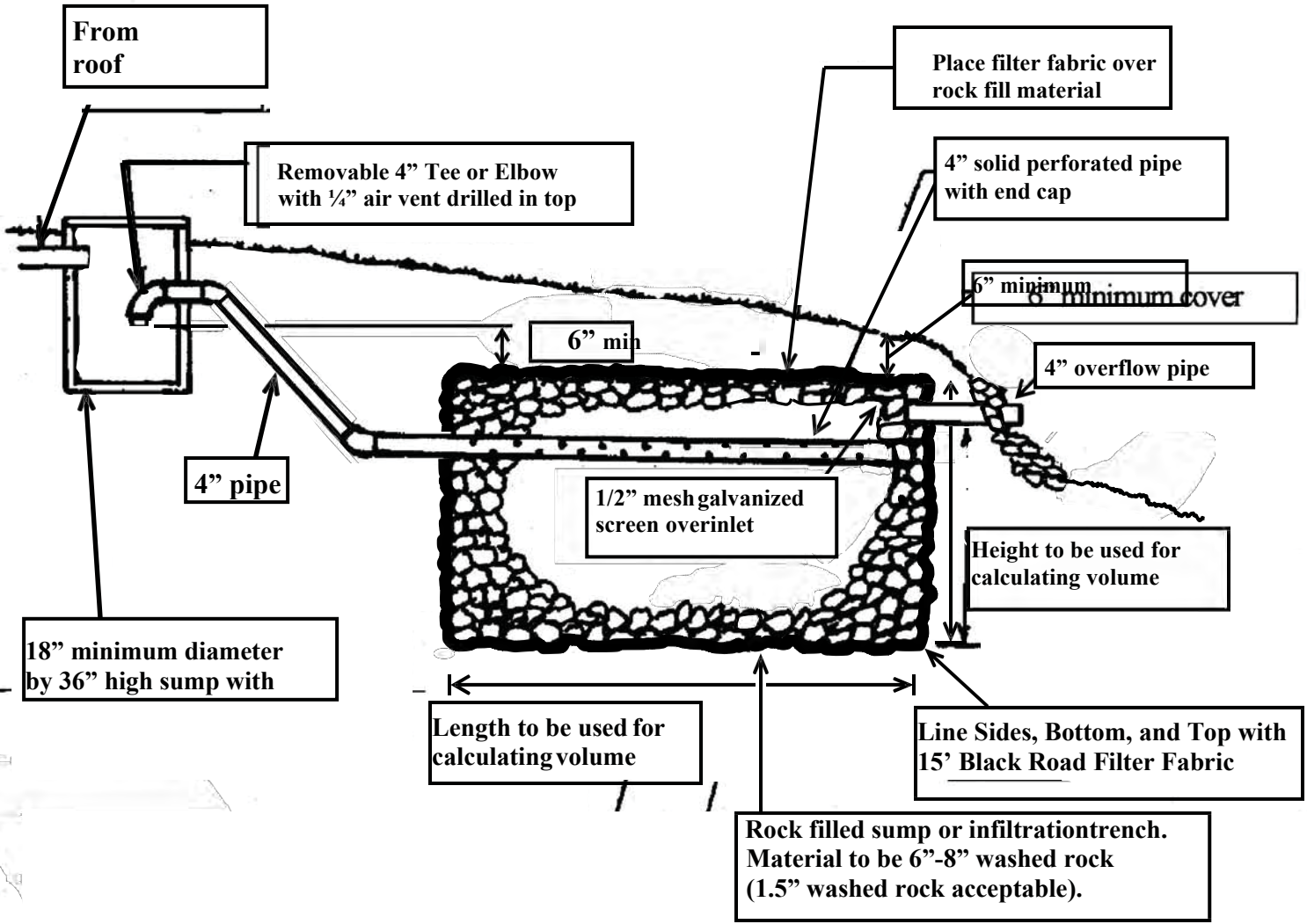

From roof

Removable 4" Tee or Elbow with 1/4" air vent drilled in top

Place filter fabric over rock fill material

4" solid perforated pipe with end cap

6" minimum cover

4" overflow pipe

6" min

4" pipe

1/2" mesh galvanized screen overinlet

Height to be used for calculating volume

18" minimum diameter by 36" high sump with

Length to be used for calculating volume

Line Sides, Bottom, and Top with 15' Black Road Filter Fabric

Rock filled sump or infiltration trench. Material to be 6"-8" washed rock (1.5" washed rock acceptable).

APPENDIX D

FENCE DESIGNS

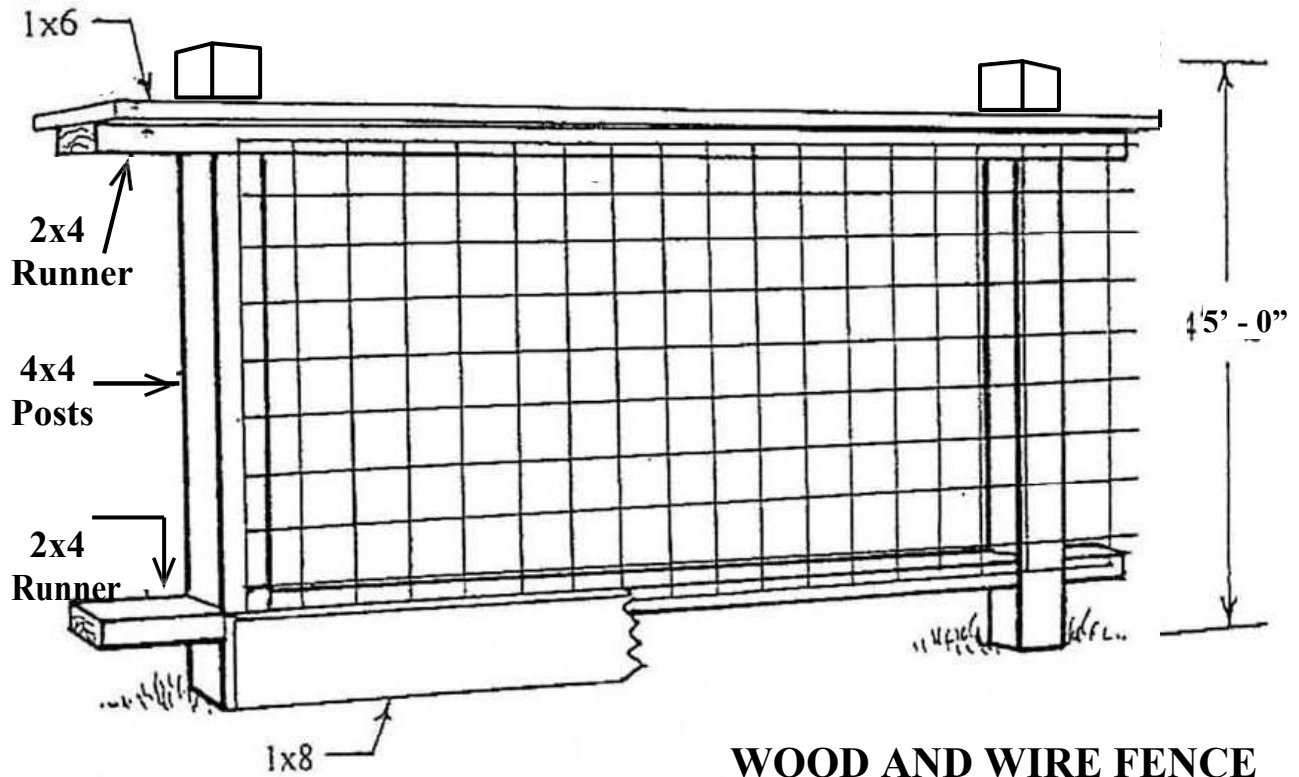

WOOD AND WIRE FENCE

The wood and wire fence is made with treated lumber and has vinyl coated black or green mesh. Use 3/4-inch "U" staples to fasten the wire mesh to the wood.

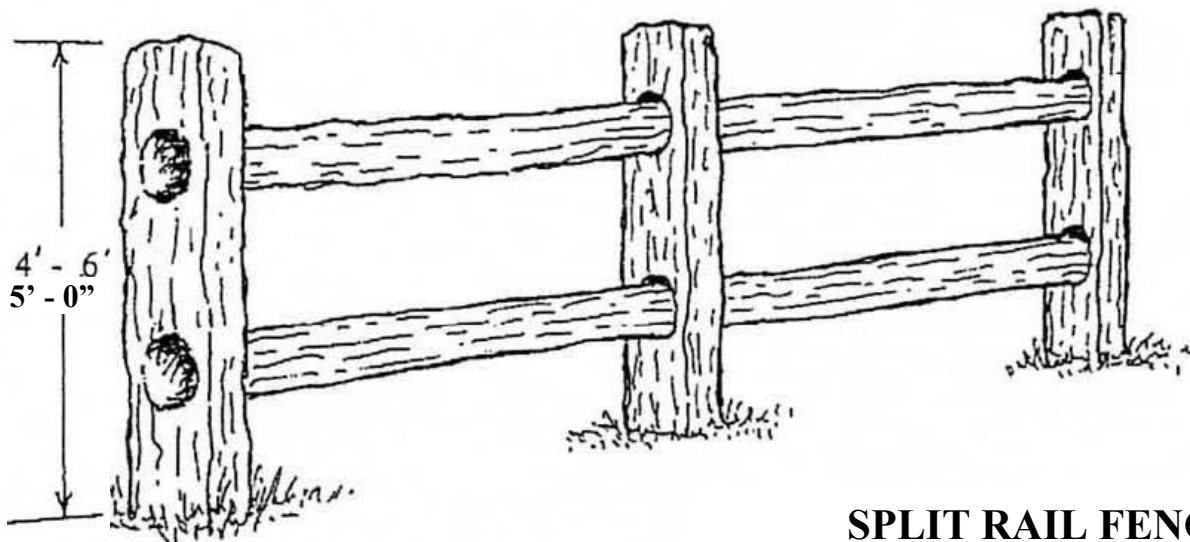

SPLIT RAIL FENCE

APPENDIX E Erosion Control

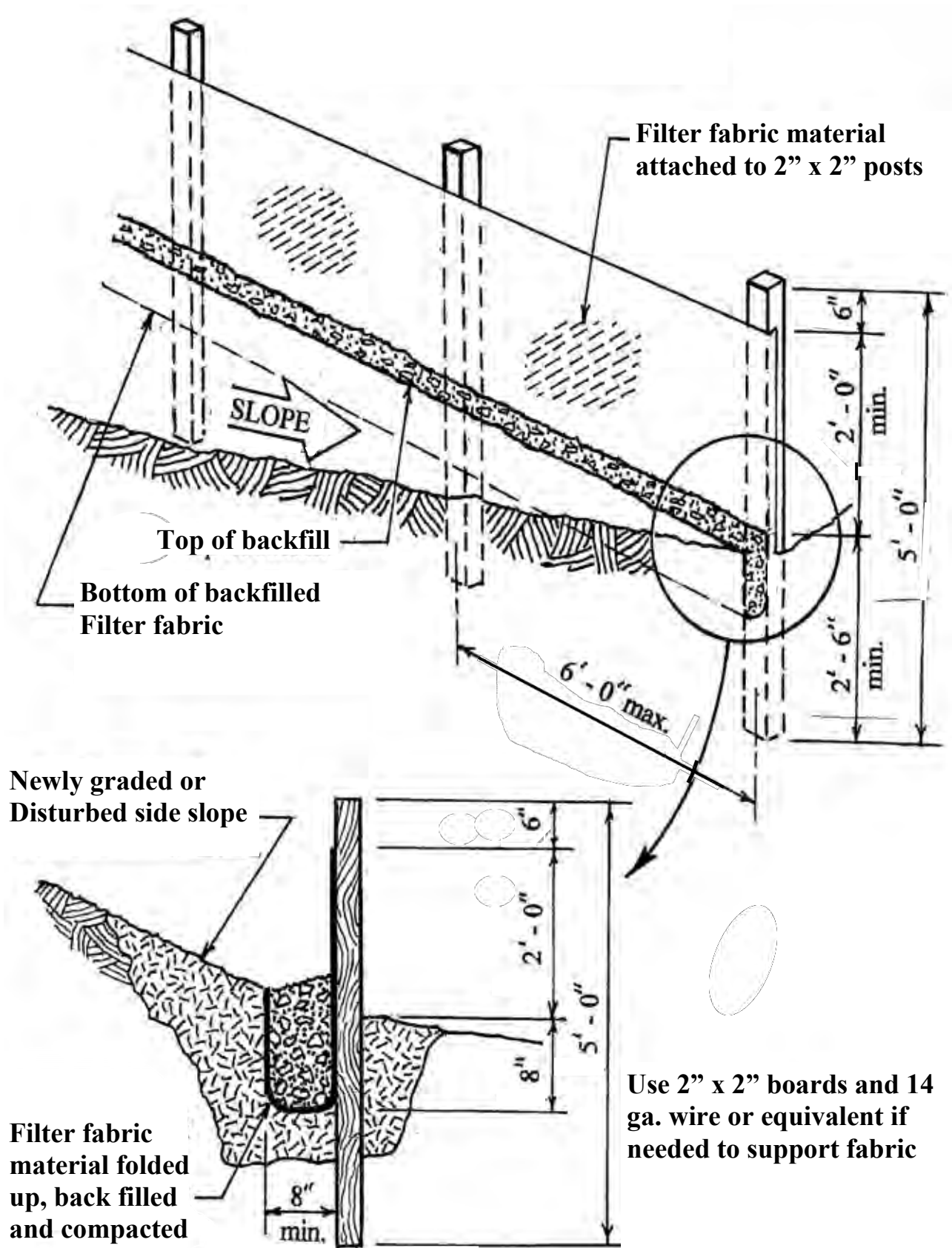

APPENDIX F

Exterior Lighting Specifications

1. Suggested styles of lighting fixtures that are down directed and where the bulb itself is shielded from view.



2. Recessed canister lights built into the eaves or canopy of a house, garage, or other building is the first choice of lighting building exteriors.



3. Flood or spot lights must be direct downward and shielded so that the bulb itself is not visible from anywhere other than the owner's property.



APPENDIX G

Exposed Concrete Specifications

Exposed concrete shall not exceed a maximum of 12" from level finished grades to bottom of siding.

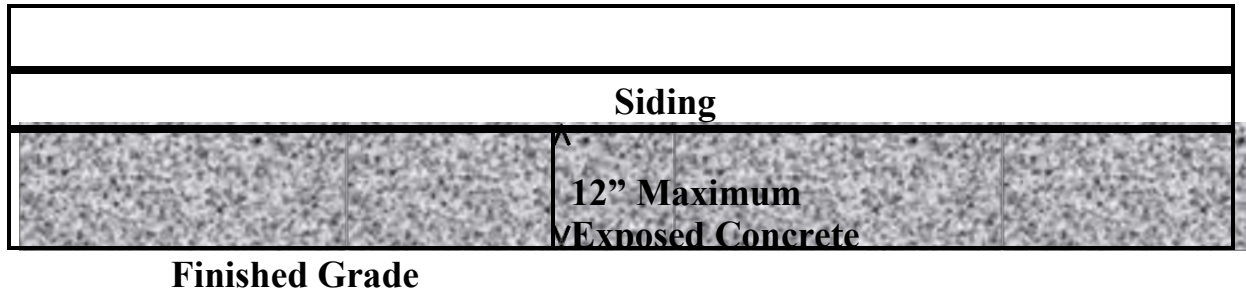

For stepped foundation walls, exposed concrete shall not exceed a maximum of 24" at any point or an average of 18" from finished grades to bottom of siding.

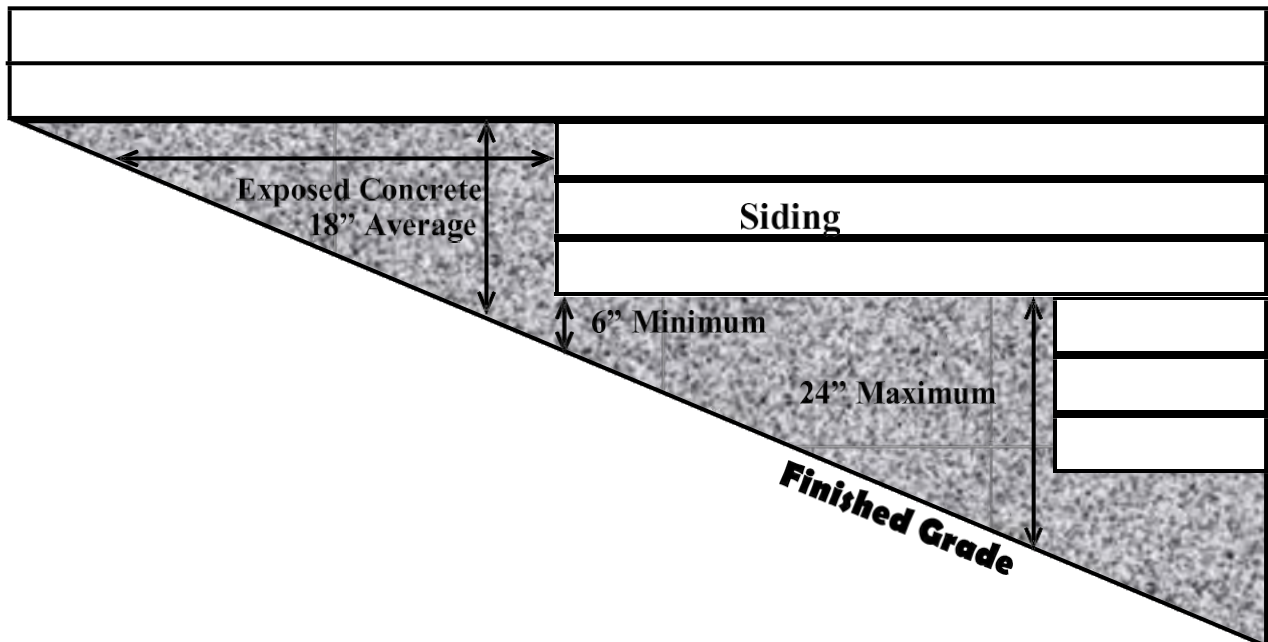

Where exceeding any of these maxima is unavoidable, foundations shall be finished in character consistent with Section 14.9.1(d) of the ACC Policies.

APPENDIX H

Propane Tank Regulations

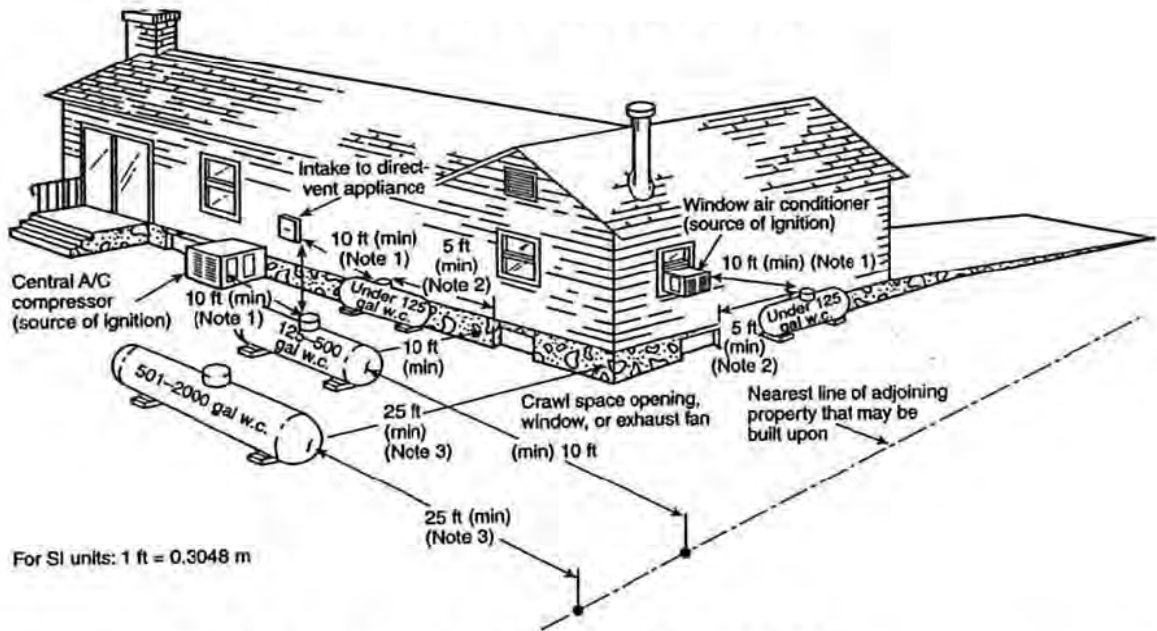

Note 1: Regardless of its size, any ASME container filled on site must be located so that the filling connection and fixed maximum liquid level gauge are at least 10 ft from any external source of ignition (e.g., open flame, window A/C, compressor), intake to direct-vented gas appliance, or intake to a mechanical ventilation system. Refer to 3-2.2.2(d).

Note 2: Refer to 3-2.2.2(c)

Note 3: This distance may be reduced to no less than 10 ft for a single container of 1200 gal (4.5 m³) water capacity or less, provided such container is at least 25 ft from any other LP-Gas container of more than 125 gal (0.5 m³) water capacity. Refer to 3-2.2.2(e).

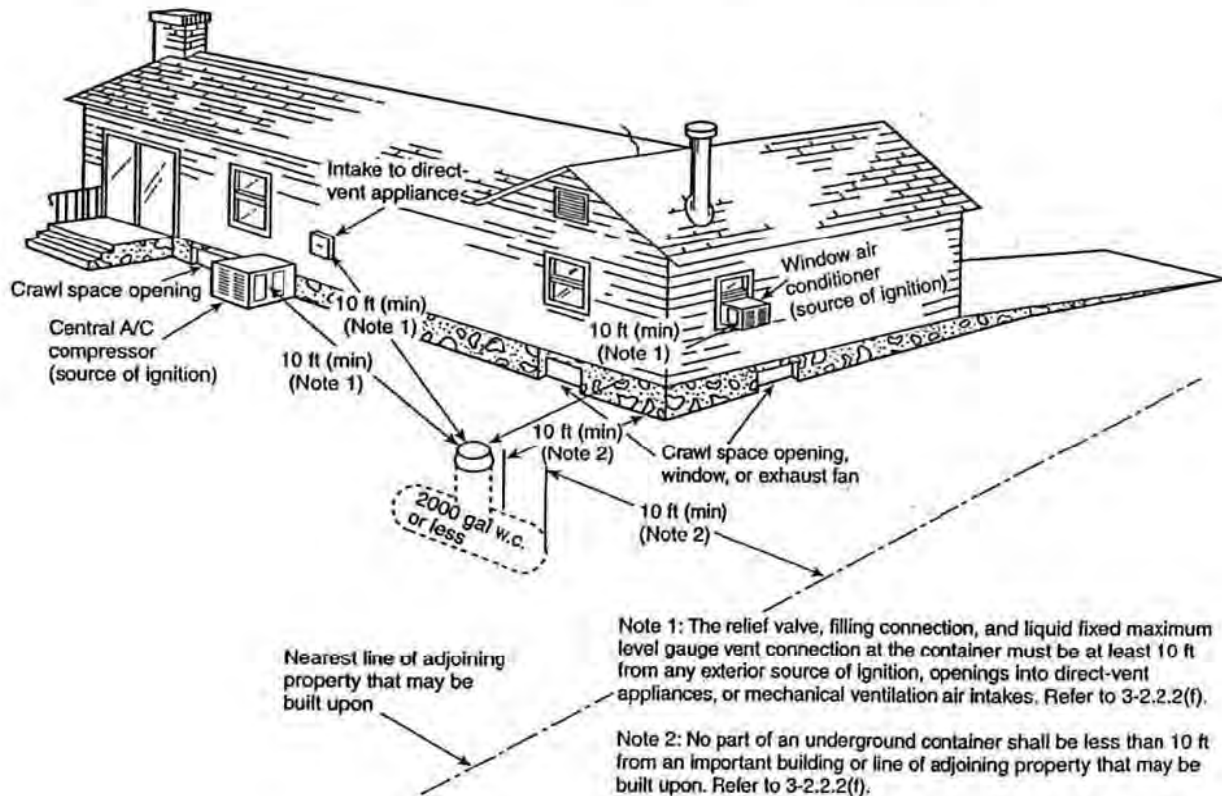

Note 1: The relief valve, filling connection, and liquid fixed maximum level gauge vent connection at the container must be at least 10 ft from any exterior source of ignition, openings into direct-vent appliances, or mechanical ventilation air intakes. Refer to 3-2.2.2(f).

Note 2: No part of an underground container shall be less than 10 ft from an important building or line of adjoining property that may be built upon. Refer to 3-2.2.2(f).

APPENDIX I

Sample Site Plan

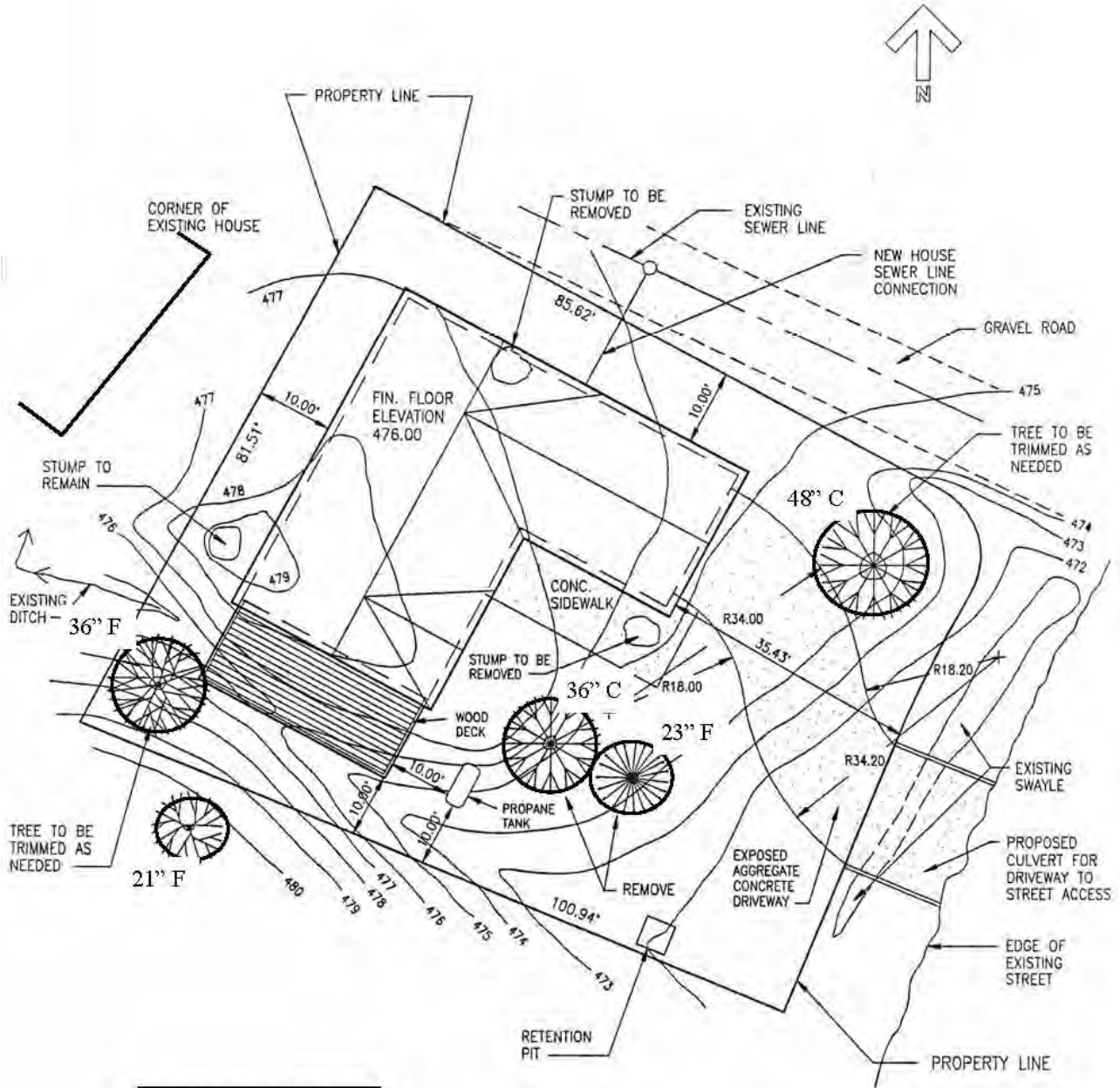

SAMPLE SITE PLAN

SCALE: 1" = 10'

NOTES:

FOR ADDITIONAL SITE INFORMATION
SEE ATTACHED TOPOGRAPHIC SURVEY

PROPANE TANK MUST BE PROPERLY LOCATED
AS PER ARTICLE 82 OF THE UNIFORM FIRE
CODE AND CANNOT BE LOCATED WITHIN THE
FRONT SETBACK OF THE PROPERTY AND MUST
MUST BE A MINIMUM OF 10 FEET FROM THE
PROPERTY LINE AND ANY STRUCTURE.

DRAWN BY:
CSD SERVICES / SUE BRAVARD

APPENDIX J

Owners' and Contractors' Checklist

Site Plan Including Landscape Details

All Plans to Include the Following Information Legend

Prepared By:

Phone Numbers:

Owners Name:

Site Address including Tax Parcel; Lot/Division:

Lot Area Sq. Footage

House Footprint Sq. Footage

Vertical Height

Living Area Sq. Footage

Garage Areas Sq. Footage

Total Impervious Surface

Driveway and Sidewalk Sq. Footage

Driveway Slope Percentage

Deck Sq. Footage

Open Space Percentage

Defined Setbacks

Elevation Landmarks

Colors for House, Trim, Accent, Garage Door, Roof; Lights

Detailed Landscape Plan to Include Tree Removal/Replanting

Whatcom County Planning Review

APPENDIX K

HOA Information

The Washington Non-Profit Corporation Act (Revised Code of Washington {RCW} 24.03)

<http://apps.leg.wa.gov/RCW/default.aspx?cite=24.03>

The Homeowners' Association Act, (Revised Code of Washington {RCW} 64.38) became effective July 23, 1995 and takes precedence over SVCA Bylaws.

<http://apps.leg.wa.gov/RCW/default.aspx?cite=64.38>

Additional Information

Whatcom County Stormwater Management Plan - Chapter 15.42

<http://www.codepublishing.com/wa/bellingham/html/Bellingham15/Bellingham1542.html>

Washington State Department of Ecology

<http://www.ecy.wa.gov>

National Fire Protection Association

<http://firewise.org>

**Note: The above sites and information are subject to change.
Please contact SVCA staff for updated information.**

APPENDIX L

THIS IS A SUDDEN VALLEY ACC-APPROVED PROJECT

Property Address:

1115

Whatcom County Code and SVCA Regulations must be complied with. Plans and related documents are required to be on site and are subject to review upon request by General Manager, Security & Compliance Manager or Construction Consultant at any time.

To report suspected violations of SVCA regulations, please contact the Security & Compliance Manager (360) 746-8437. For suspected urgent violations (blocking traffic without signs/flaggers, pouring of cement on roads, spills of potentially hazardous materials, unreasonable noise), contact Security (360) 319-8200.

Contractor Information: Company name, primary contractor name

Approved Scope:

ACC Approval Date:

Start of Construction Date:

ACC Approved Completion Date:

Hours of Operation: Monday through Saturday, 8 a.m. to 6 p.m. Work crews may begin preparation no earlier than 7:30 a.m. weekdays and 8 a.m. Saturdays. Sunday, holiday and evening work shall be limited to activities that exclude any and all machinery noise, i.e. chainsaw, excavators, power tools, etc., unless such tool use cannot be detected beyond the boundaries of the lot.

THIS SIGN IS REQUIRED TO BE DISPLAYED ON THE PROPERTY AT ALL TIMES UNTIL COMPLETION.

Sign placement shall be in accordance with ACC Policy 15.5.

APPENDIX M



FOR SALE

Realtor

Company

Phone Number

Website/ Email

APPENDIX N

Sudden Valley Tier Structure for Residence Additions and Structural Changes

See SVCA Fines and Fees Schedule for applicable fees

Defined Criteria for Additions:

- Raising Roof or Increasing Height of Structure requiring detailed Height review.
- Significant Lot encroachment, (e.g., installing a garage or carport), requiring detailed property coverage and/or Open Space reviews
- Pushing out a wall such to require Reviews of Setbacks, coverages and/or Exposed Concrete
- Any Actions requiring the lot to be resurveyed
- Any actions affecting the Driveway and its interface with Sudden Valley roads
- Installation of new Fuel Sources for items such as Generators, heat Pumps etc. requiring additional reviews/inspections.
- Retaining wall installations that would require reviews/inspections
- Any actions affecting Sudden Valley Right-of-Way.

Tiers and Reviews/Inspections

- Tier 1 – Additions Not affected by defined criteria
- Tier 2- Additions that are affected by not more than three (3) defined criteria excluding Driveway changes
- Tier 3 – Additions that are affected by four (4) or more defined criteria and/or driveway changes.

	Preliminary	Compliance	Setback	Driveway	Final
Tier 1	N	Y	P	N	Y
Tier 2	Y	Y	P	P	Y
Tier 3	Y	Y	P	P	Y

APPENDIX O

Pre-Approved Sherwin Williams Exterior Paint Colors

For Trim:

Neutral Ground SW 7568

Drift of Mist SW 9166

Pure White SW 7005

Alabaster SW 7008

For Body:

Olympic Range SW 7750

Attitude Gray SW 7060

Pavestone SW 7642

Cyberspace SW 7076

Aurora Brown SW 2837

Acier SW 9170

Mount Etna SW 7625

Urbane Bronze SW 7048

Well-Bred Brown SW 7027

Universal Khaki SW 6150

Roycroft Copper Red SW 2839

Repose Gray SW 7015

Shade-Grown SW 6188

Westchester Gray SW 2849

Taupe Tone SW 7633

Naval SW 6244

Peppercorn SW 7674

Clary Sage SW 6178

Pewter Green SW 6208

Jade Dragon SW 9129

Dried Thyme SW 6186

Double Latte SW 9108

Underseas SW 6214

ACC Policies - Guide to Changes 4/23/2024

Topic	Policy Number	Date Revised	Description of Change
Introduction - Page 4			Changes for clarity; added language to emphasize that SVCA's approval is separate from and may be more restrictive than County approval
Definitions - Page 5		7/1/2015	Added definition for ADU
Statement of principle	13.1	7/1/2020	No change
Committee Structure	13.2	7/1/2020	Corrected to align with Bylaws Section 2 (a).
Powers	13.3	7/1/2020	Added mention that the Committee considers each property individually and that variances granted in one situation may not be granted in another.
Commission	13.4	7/1/2020	Added language to allow ACC Inspector or other staff member to inspect completed exterior alteration requests.
Area of Responsibility	13.5	7/1/2020	No change
Purpose	13.6	7/1/2020	No change
Objectives	13.7	7/1/2020	Added reference to signage and called out oversight of single-family homes
ACC meetings/agendas	13.8	7/1/2015	Review of bylaws determined it is OK for ACC to deviate from the board's practice of 48 hrs notice. Increased the time allowed for sending decisions and posting minutes because of higher volume of building and remodels.
Intent	14.1	7/1/2015	Deleted outdated reference to tract housing and to the use of "off the shelf" plans for new construction. Change is for succinctness and to put emphasis on the house design fitting the lot.
Scope	14.2	7/1/2015	Promote openness to diverse design ideas and construction methods.
Compliance Review	14.3	7/1/2015	Maintenance & Facilities Manager is has oversight and signs-off on the final approval of the REPA which is SVCAs authorization to proceed. This clarifies the process and ensures the Maintenance & Facilities Manager is consulted.
Contractor Requirements - Licensing	14.4.1	7/1/2015	No change
Contractor Requirements - Portable Toilet	14.4.2	7/1/2015	No change
Contractor Requirements - Trash Removal	14.4.3	7/1/2015	No change
Contractor Requirements - Speed Limits	14.4.4	7/1/2015	No change
Contractor Requirements - Track-type Vehicles	14.4.5	7/1/2015	No change
Contractor Requirements - Concrete Trucks	14.4.6	7/1/2015	No change
Contractor Requirements - Fire Prevention	14.4.7	7/1/2015	This creates a minumun standard for fire extinguishers which is measurable, in addition to a more appropriate timeline for on-site water, rather than the time of footing inspection, which is done by county.
Contractor Requirements - Violations	14.4.8	7/1/2015	No change
Site and lot requirements - Open Space	14.5.1	7/1/2015	While variances are still available, the open space allowed for many new constructions does not fit the lot or surrounding properties.

Site and lot requirements - Setbacks	14.5.2	7/1/2015	While variances are still available, the setbacks allowed for many new constructions does not fit the lot or surrounding properties. With properties that are only 10 feet apart, there are more applications for privacy fences and neighbor tree removal for safety reasons.
Site and lot requirements - Area & Density	14.5.3	7/1/2015	No change
Site and lot requirements - Vision Clearance	14.5.4	7/1/2015	No change
Site and lot requirements - Driveways	14.5.5	7/1/2015	Safety is the main reason for slope change however many residents with driveways sloped over 20%, request the addition of a street parking space or park next to or in the street.
Site and lot requirements - Parking	14.5.6	7/1/2015	REPA process added to obtain approval of Maintenance & Facilities Manager
Site and lot requirements - Drainage	14.5.7	7/1/2015	REPA process added to obtain approval of Maintenance & Facilities Manager; changed the responsibility for maintaining culverts to homeowner.
Site and lot requirements - StormWater	14.5.8	7/1/2015	Changes bring SVCA requirements in line with Whatcom County code.
Site and lot requirements - Cluster Lots	14.5.9	7/1/2015	No change
Structure requirements - Minimum Space	14.6.1	7/1/2015	While allowing latitude for designing the house to the lot, there is still a restriction on building a size limit
Structure requirements - Height	14.6.2	7/1/2015	While variances are still available, the construction heights allowed for many new constructions do not fit the lot or surrounding properties. Height calculations were unchanged but included is the reminder that surrounding properties will be considered with approvals.
Structure requirements - Exterior Finishes	14.6.3	7/1/2015	No change
Structure requirements - Exterior Lighting	14.6.4	7/1/2015	LED flat panel lights have been a recent and common complaint, while mercury vapor lights are no longer common. The prohibition of these lights is easier than trying to make a judgement call on a case-by-case basis.
Structure requirements - Accessory Structures	14.6.5	7/1/2015	Edited for clarity. Removed requirement for resubmittal after 6 months.
Structure requirements - Solar Panels	14.6.6	7/1/2015	No change
Structure requirements - Hot Tubs	14.6.7	7/1/2015	Add requirement for screening hot tub from adjacent property and roads. ACC gets requests for privacy screens from neighbors not wanting to be privy to neighbors HT parties.
Structure requirements - Propane Tanks	14.6.8	7/1/2015	No change
Structure requirements - Fences	14.6.9	7/1/2015	The Fence Request Submission process is detailed on the form.
Hours of operation	14.7.1	8/1/2018	Inserted Policy 2018.03 to this section and added a specific reference to radios/non-equipment generated noise.
Lot clearing/Excavation	14.7.2	7/1/2015	Updated references to staff with current titles. Other revisions for clarity. Removed reference to a "proposed" pre-construction investigation process.
Erosion control	14.7.3	7/1/2015	No Change
Parking	14.7.4	7/1/2015	No Change

Inspections	14.7.5	7/1/2015	Making the erosion control time-bound adds clarity to the requirement, and makes it measurable. The storm water inspection has been discontinued due to liability, this change removes the language from the policy. Redefining the permit and extension timelines simplifies the process for all parties, and no longer attaching it to county permit dates creates an equal timeline for all builds.
Re-inspections	14.7.6	9/1/2020	No change
Construction time limits	14.7.7	4/1/2017	No change
Construction submittals	14.8.1	7/1/2015	Inserted abbreviated version of SVCA Policy 1996.17
Construction Application	14.8.2		Requiring two physical copies, reviewing and giving one back to the submitter is no longer necessary with the ability for digital reviews and revisions. One physical set is still required to be retained by SVCA for archives. Whatcom county does digital-only submissions.
Preliminary Review	14.8.3		Added statement that this review is non binding.
Deadline & Completeness	14.8.4		No change
Other requirements	14.8.5		The wrong section was being referenced.
Compliance & Review	14.8.6		With the inclusion of digital submittals and reviews, only one physical copy needs to be retained for SVCA archives, so there is no second copy to be returned to the owner.
Quality & Content	14.8.7		Retitled sections for clarity
Fees	14.8.8	7/1/2015	Updated to reflect current fee structure.
Completion deposits for new construction	14.8.9	7/1/2015	No Change
Survey	14.8.10	7/1/2015	No Change
Site Prep	14.8.11		Stringing the outline of the structure assists ACC members and AC inspector visually review the proposal. Sometimes topography or vegetation make it difficult.
Utilities	14.8.12	7/1/2015	No Change
Variances	14.8.13	7/1/2015	Adding the expiration to the variance approval adds clarity and specifies that the approval is not indefinite.
Landscaping	14.9		Incorporated 14.9.2 in this section and deleted 14.9.2 for clarity
Native Vegetation	14.9.1 - a	7/1/2015	Revisions for clarity
Trees	14.9.1 - b		Clarifies and specifies tree protection measures to International Society or Arboriculture standards which are measureable, and to simplify the inspection process while providing adequate tree protection. Creates a minimum standard size which is measurable for replacement trees aligned with Whatcom county standards.
Slopes	14.9.1 - c		No change
Retaining Walls	14.9.1 - d		No change
Debris removal	14.9.1 - e		Added specific restriction on dumping landscape debris
Erosion control	14.9.1 - f		No change
Landscape fabrics	14.9.1 - g		Mulch made from ground rubber tires is not environmentally friendly.
Replanting	14.9.1 - h		Establishing minimum standard sizes for trees is measurable, and encourages existing tree retainment. A larger planted tree is more likely to be watered and survive than a small sapling.
Edging	14.9.1 - i		No change
gardening in ROW	14.9.1 - j		No change

Noxious weeds	14.9.1 - k		Added reference to proposed new appendix listing noxious weed sites
Vegetable Gardens	14.9.1 - l		Deleted
Landscape Plan	14.9.2		Section incorporated into 14.9.1 and deleted
Tree Removal	14.10		14.10.3 updated to identify Area Z woodcutting site.
Removal Criteria	14.10.1		
Submittal	14.10.2		
General Practices	14.10.3		
Pruning	14.10.4		
Emergency Remova	14.10.5		
Property maintenance	14.11	7/1/2015	
Developed Property	14.11.1		
Tree & Brush	14.11.2		
Storm water Retention System Design	14.11.3		
Address	14.11.4	7/1/2015	
Exterior Storage	14.11.5		
Replacement of damaged structures	14.11.6	7/1/2015	
Signs - General	15.1	1/1/2018	No change
Signs - Address	15.2		
For Sale/Rent	15.3		
Open House	15.4		
Construction	15.5		
Other signs	15.6		
Political Signs	15.7		
American Flag	15.8		
Penalties	15.9		
Enforcement	16	7/1/2015	
Fines	17	7/1/2015	No change
Driveway and Culvert Specs.	Appendix A	7/1/2015	
Height Regulations and Definitions	Appendix B	7/1/2015	
Storm water Retention System Design	Appendix C	7/1/2015	
Fence Designs	Appendix D	7/1/2015	Fixed heading
Erosion Control	Appendix E	7/1/2015	
Outdoor Lighting Specs.	Appendix F	7/1/2015	
Exposed Concrete Specs.	Appendix G	7/1/2015	
Propane Tank Regulations	Appendix H	7/1/2015	
Sample Site Plan	Appendix I	7/1/2015	
Checklist	Appendix J	7/1/2015	
HOA Information/Dept. of Ecology/National Fire Protection Association	Appendix K	7/1/2015	
Construction Signs	Appendix L	1/1/2018	
For Sale / Rent Signs	Appendix M	1/1/2018	

Sudden Valley Tier Structure for Residence Additions and Structural Changes	Appendix N	2/1/2019	
Pre-Approved Paint Colors	Appendix O	2/1/2019	

Site and lot requirements – Driveways

14.5.5



Fill with gravel (please see estimate in email file) We would like to fill in this area with gravel, so my wife can easily park her car. **She is scared to park her car in the sloped driveway.** She calls me (her husband) every time to properly park the car in our sloped driveway. It is dangerous in the rain and the winter, and we have three small children who we want to keep safe. This gravel filled area would help keep our family safe during the extreme weather in SV. This will not impact the drainage, it will only help my family. Contractor is licensed, insured, and bonded.

Site and lot requirements – Driveways

14.5.5

AC Inspector Notes:

- These plans have been revised to meet ACC policies, with exceptions noted below:
1. The driveway slope is indicated at 26.8%, and the maximum driveway slope per the ACC policies is 25% without a variance. I have recommended the builder reduce the slope or submit a variance.

Site and lot requirements – Driveways

14.5.5

Current

A maximum driveway slope shall not exceed 25%.

Proposed

A maximum driveway slope shall not exceed 15% or 20% if grooved.

Site and lot requirements – Driveways

14.5.5

Table 505 - 4 - Private Roadway or Driveway

Private Roadway or Driveway								
Designation	Setting	Incremental Grade, %	Minimum Surface Treatment	Minimum Roadway Width, ft	Unobstructed Minimum Vertical Clearance, ft	Minimum Turning Radii, ft		See also Standard Drawing(s)
						Inside	Outside	
Driveway ⁽¹⁾	Rural & Urban	<12	CSTC ⁽²⁾	12	13.5	25	40	505.E-6
		12 to <15	Paved ⁽³⁾					
		15 to 18	Grooved PCC ⁽⁴⁾					
Private Roadway	Rural	<12	CSTC ⁽²⁾	20 ⁽⁵⁾	13.5	25 ⁽⁶⁾	45 ⁽⁶⁾	505.E-1
		12 to <15	Paved ⁽³⁾					
		15 to 18	Grooved PCC ⁽⁴⁾					
	Urban	<12	Paved ⁽³⁾	20 ⁽⁵⁾				505.E-2
		12 to <15	Paved ⁽³⁾					
		15 to 18	Grooved PCC ⁽⁴⁾					

⁽¹⁾ Driveway serves up to 20 ADT (or two dwelling units)

⁽²⁾ Crushed surfacing top course

⁽³⁾ Either Portland Cement Concrete (PCC) or Hot Mix Asphalt (HMA)

⁽⁴⁾ Portland Cement Concrete

⁽⁵⁾ See Standard Drawing(s) for when additional width is required

⁽⁶⁾ See also 505.I.3 – Horizontal Curves

[County Link](#)

Site and lot requirements – Setbacks

14.5.2



No space for privacy screen

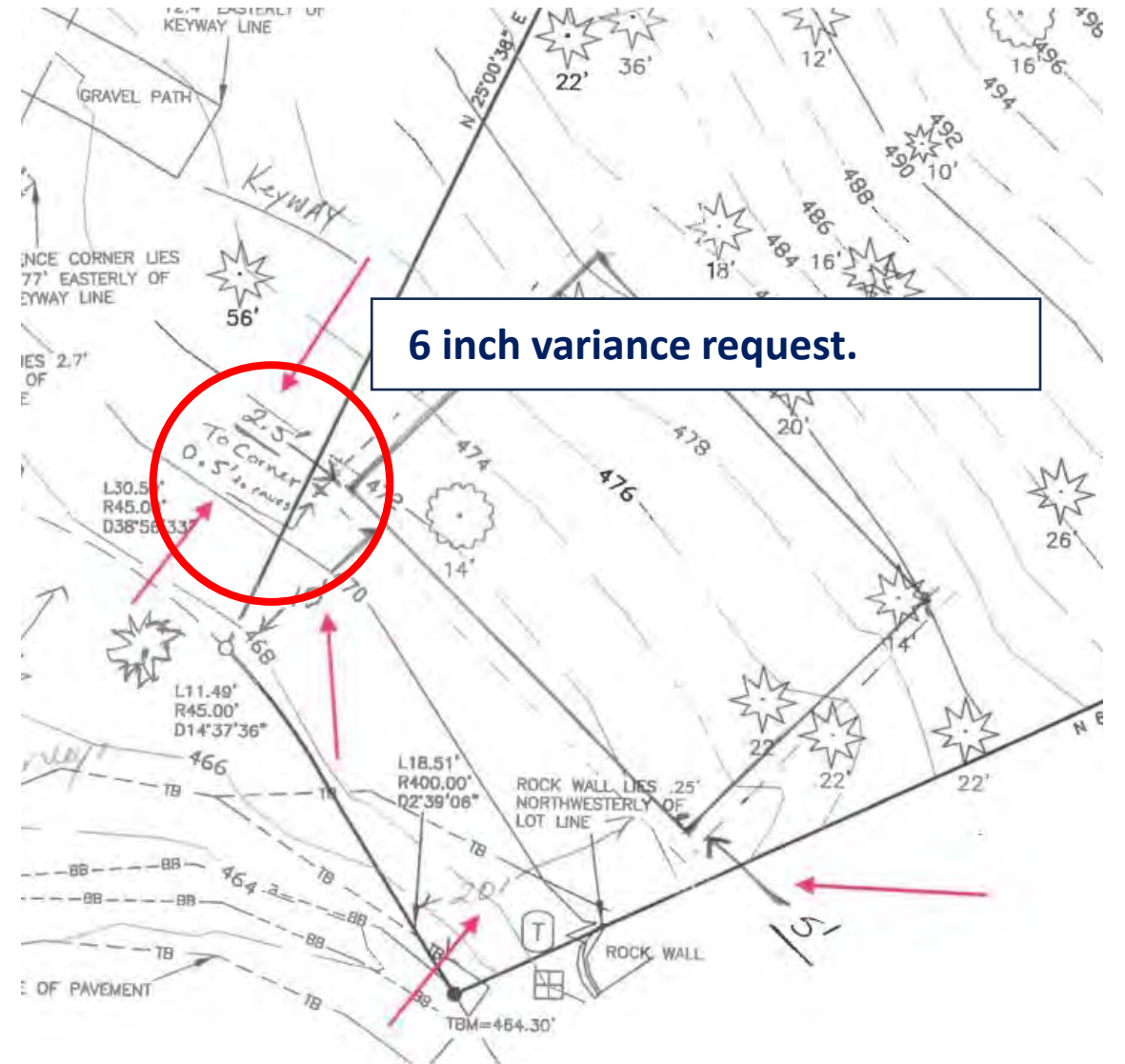

Site and lot requirements – Setbacks

14.5.2

Current

Minimum Sudden Valley setbacks are as follows:

Front - Twenty (20) feet from right-of-way

Rear - Five (5) feet.

Interior Side - Five (5) feet.

Proposed

Minimum Sudden Valley setbacks are as follows:

Front - Twenty (20) feet from right-of-way

Rear - Five (5) feet.

Interior Side - At least Five (5) feet.

Combined Interior Side setbacks must be at least twenty (20) feet.

Property Coverage and Open Space Requirements:

14.5.1

Additional requirement

Property Coverage Rule - The principle building and accessory structure footprint, inclusive of eave projections **and driveways** and exclusive of decks, shall occupy no more than thirty-five percent (35%) of the lot.

Property Coverage and Open Space Requirements:

14.5.1

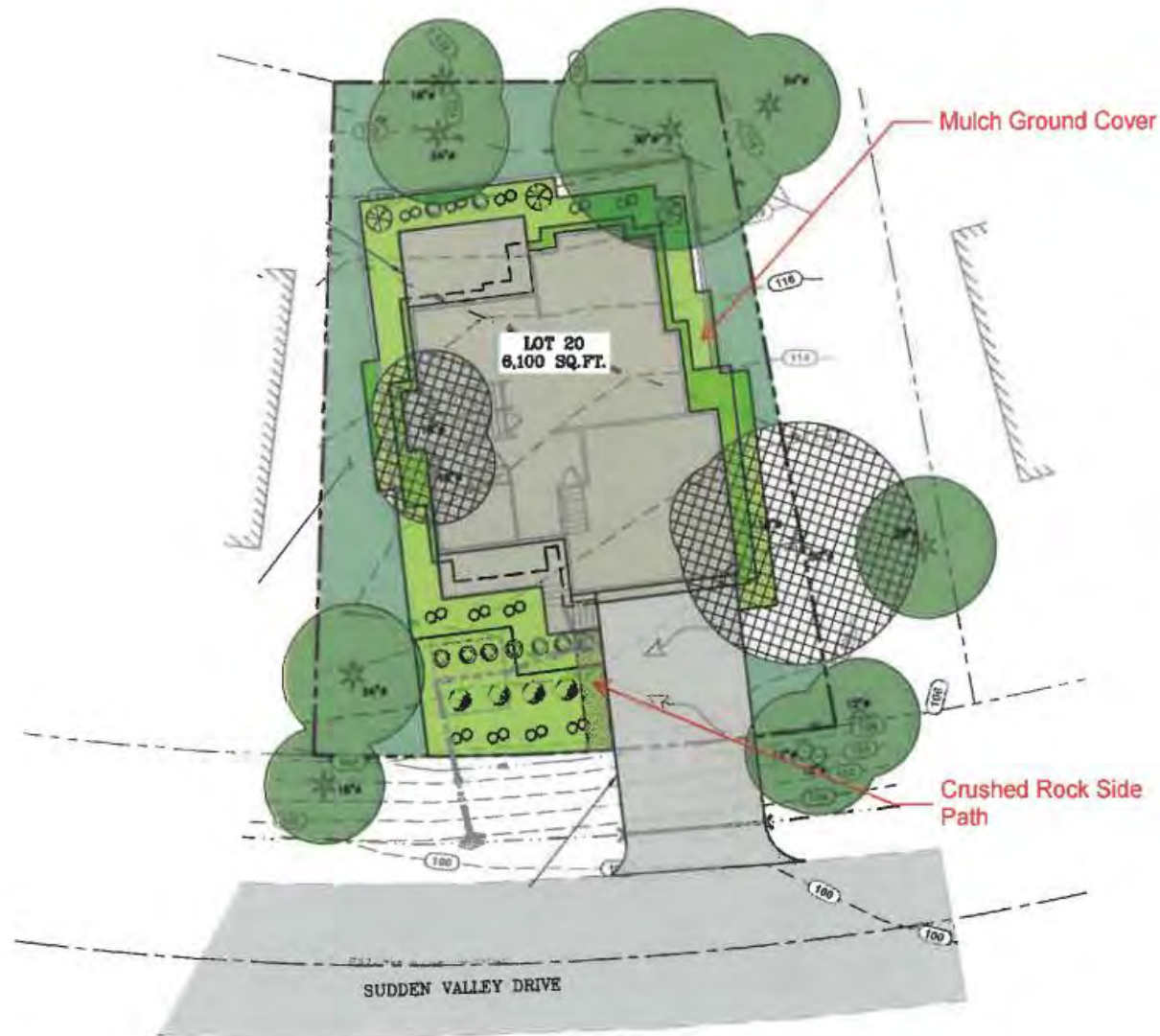

Height: Definition 1 (30 ft. max) @5ft:
Definition 2 (20ft. max) @ 10 ft: **19.3'**

Driveway Slope: (25% max): **26.8%**

Property Coverage: (35% max): **34.6%**

Open Space: (50% min): **55%**

Structure requirements - Hot Tubs

14.6.7

Additional requirement

Hot tubs must be screened from view of adjacent properties and roads by a privacy panel or similar design consistent with the design of the main structure (house).

Structure requirements - Hot Tubs

14.6.7

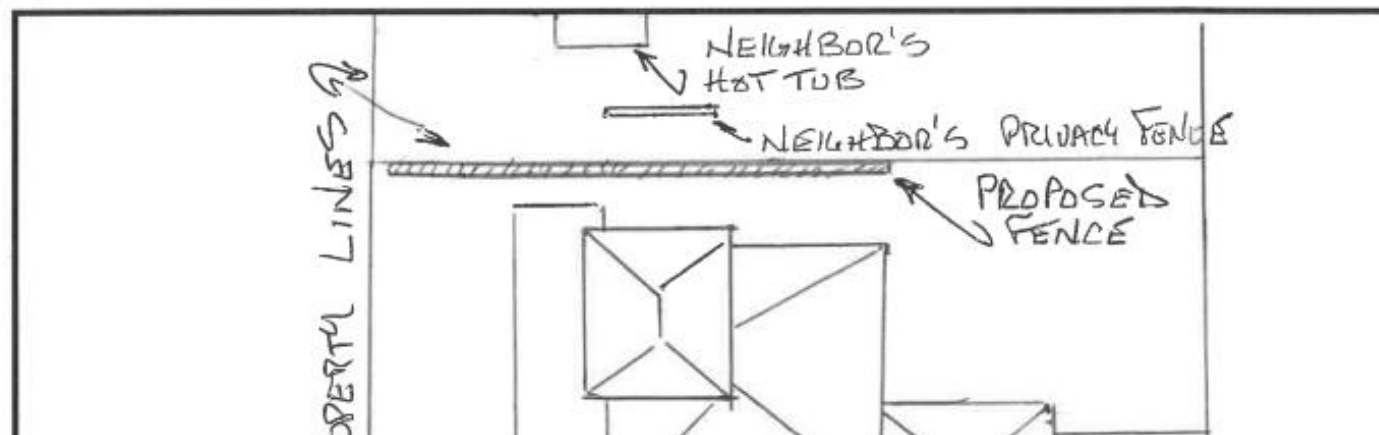

Give a full description, additional considerations, and attach additional information if needed:

PRIVACY FENCE IS REQUESTED ALONG SW PROPERTY LINE, AS SHOWN, TO BLOCK NEIGHBOR'S HOT TUB (FULL VIEW) * DESPITE NEIGHBOR'S "PRIVACY FENCE". FENCE TO BE BUILT ATD STE. WALL

AC Staff Comments:

*NOTE: NEIGHBOR USES HOT TUB WITHOUT CLOTHING, IN FULL VIEW FROM OUR DINING ROOM & DECK. WE HAVE GRANDKIDS AND GUESTS WITH CHILDREN IN OUR HOME.
PICS UPON REQUEST